

NOTES:

- ITEM 100520095 NOT SHOWN

REVISIONS

REV	DESCRIPTION	DATE	BY	ECO #
A	RELEASED	07/28/2022	EGH	AIR-1135
B	ADDED MOUNTING HARDWARE 100506848 QTY 8, 100506208 QTY 4, 100506733 QTY 4, AND INSTRUCTION SHEET 100520095 QTY 1, ADDED SALES DRAWING PAGE	09/08/2022	KCH	AIR-1110
C	SHEET METAL REDESIGN AND HARDWARE CHANGE	04/17/2023	KCH	AIR-1292
D	CORRECTING DRAWING VIEW TO REMOVE UNIT SHOWN	05/01/2023	KCH	AIR-1292

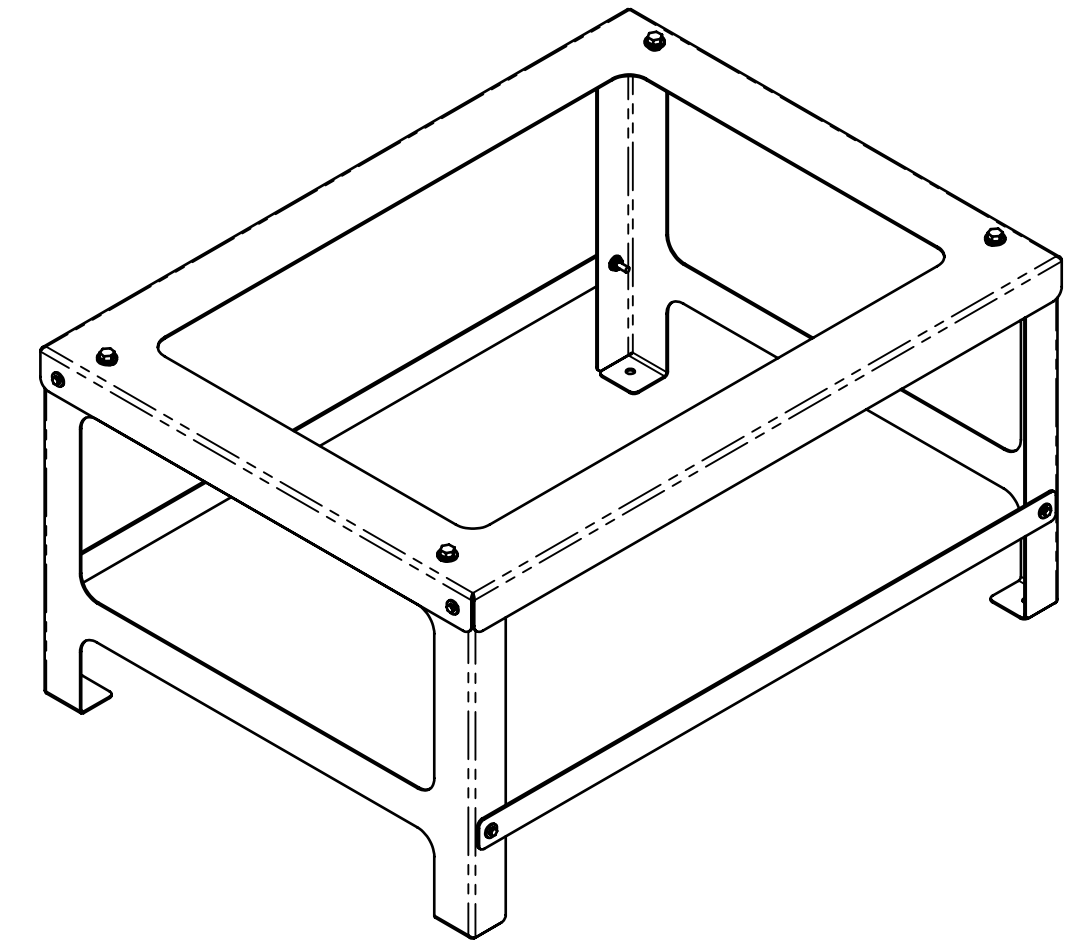
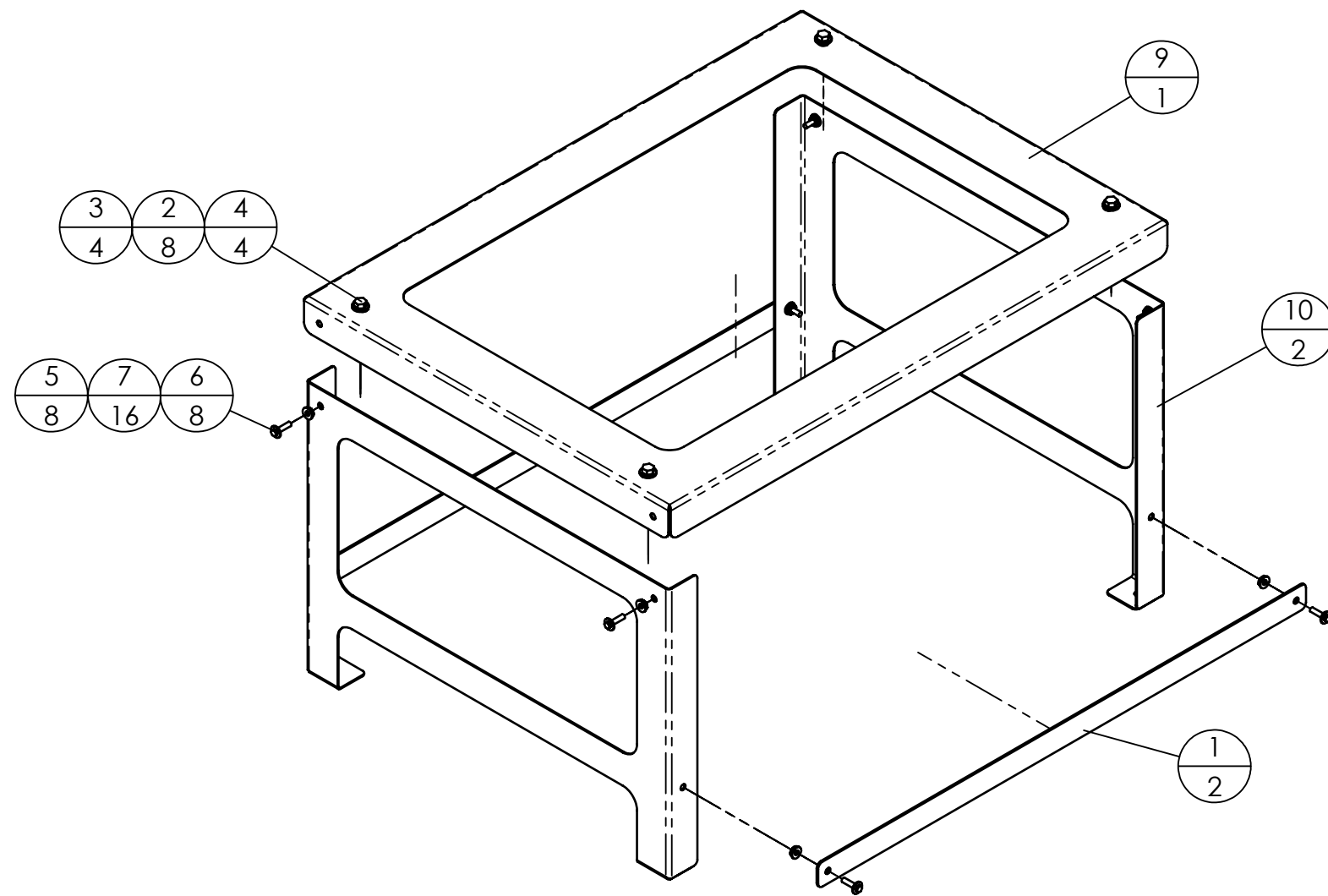

ITEM	QTY	PART NUMBER	DESCRIPTION
10	2	100520745	SHEET METAL, RAD 150-200, SIDE PANEL, 25.29 IN L, 17.58 IN W, 2.00 IN H, CRS
9	1	100520744	SHEET METAL, RAD 150-200, TOP PANEL, 34.79 IN L, 25.57 IN W, 2.00 IN H, CRS
8	1	100520095	INSTR - AFS ASSEMBLY GUIDE
7	16	100500968	WASHER FLAT, 1/4 SAE
6	8	100506728	SCR-C HH,G5,1/4-20 X 1, ZN
5	8	100506222	NUT-KEP,G5,1/4-20,REG
4	4	100506733	SCR-C HH,G5,3/8-16 X 1, ZN
3	4	100506208	NUT-HEX,G5, 3/8-16,REG ,CZ
2	8	100506848	WSHR-FLT, 3/8,A,WIDE ,YZN
1	2	100520148	BRKT, L & R CROSS BRACE, RAD FLOOR STAND, 0150-0200

DRAWN: E.GALINDO APPROVED: K.HOERR DATE: 07/28/2022 MATERIAL: FINISH:	UNLESS OTHERWISE NOTED, TOLERANCES ARE: FRACTIONS: 1/16 ANGLE: ±1° DECIMAL: .X = ±.06 .XX = ±.03 .XXX = ±.015 .XXXX = ±.0030 MACHINED SURFACES: 125 MICRONS THESE TOLERANCES DO NOT APPLY TO BASIC DIMENSIONS. DO NOT SCALE THIS PRINT, REMOVE ALL BURRS & SHARP EDGES. ALL DIMENSIONS ARE IN INCHES. CAD SOFTWARE: SOLIDWORKS. DRAWING DIMENSIONED TO ALTEC STANDARD: CDS-0007.	226A COMMERCE ST, BROOMFIELD, CO 80020
TITLE: KIT, RAD FLOOR STAND, RAD-0150-0200		
SHEET 1 OF 2	SCALE: 1:8 WEIGHT: 25.3 SIZE: 3	NUMBER: 100520144 REV: D

RAD-0200 SHOWN FOR REFERENCE ONLY AND IS NOT INCLUDED WITH FLOOR STAND

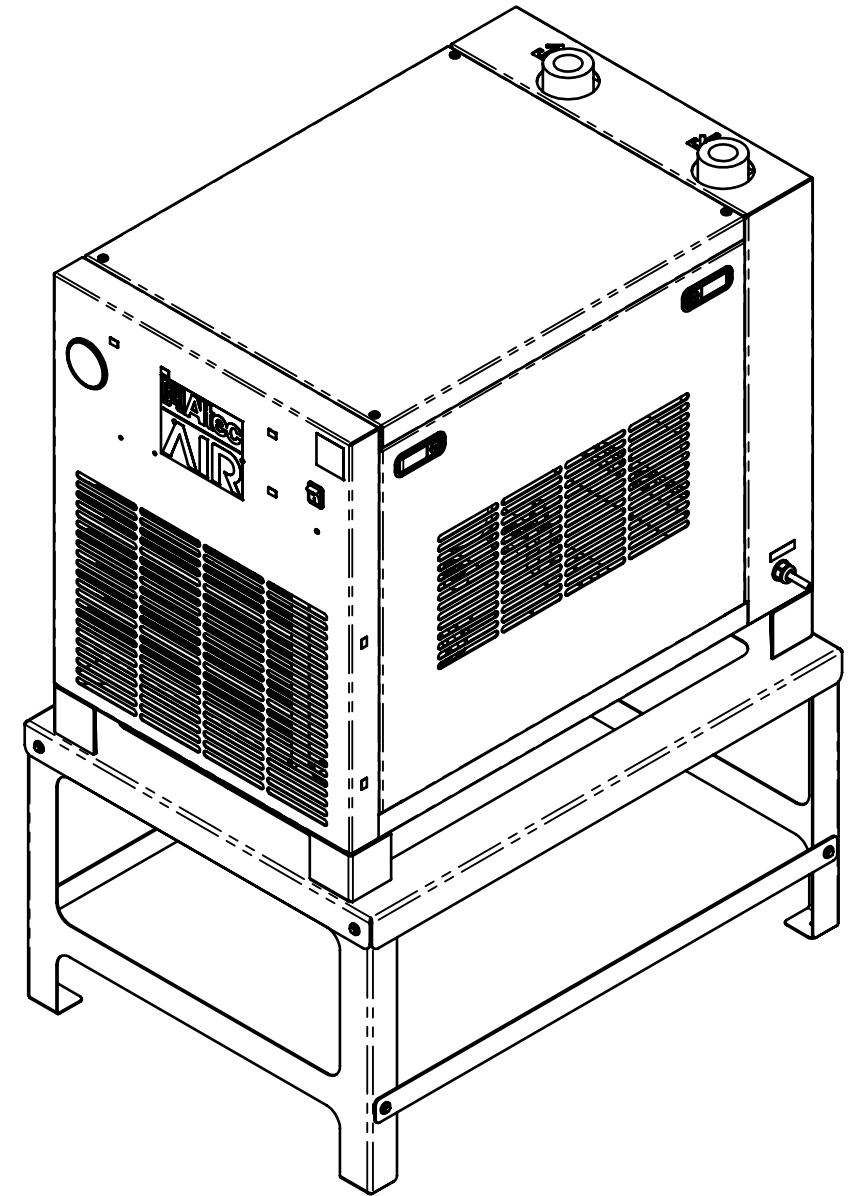
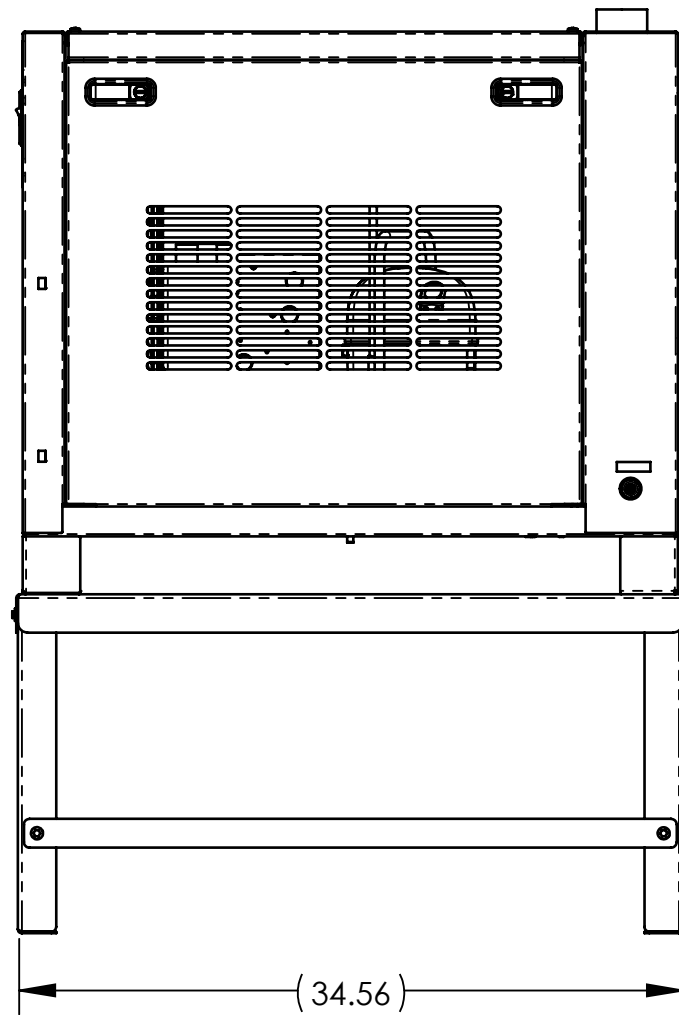
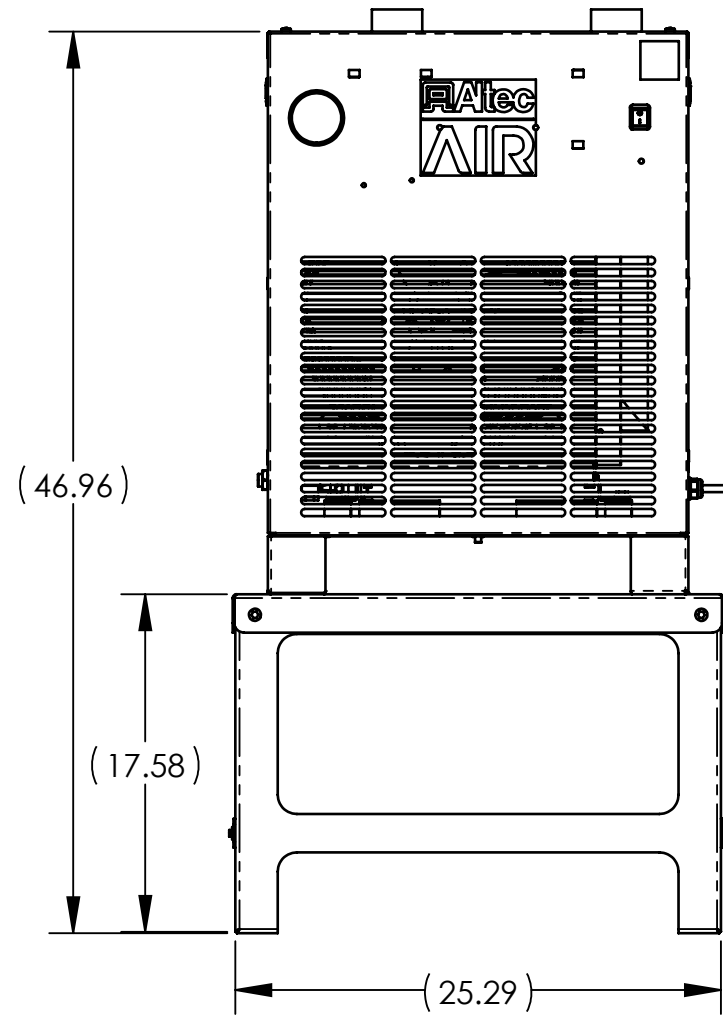

DRAWN E.GALINDO	UNLESS OTHERWISE NOTED, TOLERANCES ARE: FRACTIONS: $\pm 1/16$ ANGLES: $\pm 0^{\circ}30'$ DECIMAL: .X = $\pm .06$.XX = $\pm .03$.XXX = $\pm .015$.XXXX = $\pm .0030$ MACHINED SURFACES: 125 MICROINCHES THESE TOLERANCES DO NOT APPLY TO BASIC DIMENSIONS.
APPROVED K.HOERR	
DATE 07/28/2022	DO NOT SCALE THIS PRINT, REMOVE ALL BURRS & SHARP EDGES, ALL DIMENSIONS ARE IN INCHES. CAD SOFTWARE: SOLIDWORKS. DRAWING DIMENSIONED TO ALTEC STANDARD: CDS-0007.
MATERIAL -	TITLE: KIT, RAD FLOOR STAND, RAD-0150-0200
FINISH -	
SHEET 2 OF 2	CONFIDENTIAL: This drawing and its contents are the proprietary and confidential information of Altec Industries, Inc. and are not to be reproduced, copied or publicly disclosed. If this drawing is provided to someone outside Altec, it is done so for the limited purpose of assisting that recipient with a technical or product issue. In receiving this drawing, the recipient agrees to maintain it in confidence and not to use it beyond the purpose previously stated. Recipient agrees not to reproduce, copy, or publicly disclose this drawing and its contents.

Atec | AIR
226A COMMERCE ST, BROOMFIELD, CO 80020

SCALE	WEIGHT	SIZE	NUMBER	REV
1:10	191.3	2	100520144	C