

P1500W Series Air Dryers



User's Guide

Models covered:

P1500W

P1500WLP

P1500WHP

P1502W

P1502WLP

P1502WHP





WARNING:

This product can expose you to chemicals including Lead, which is known to the State of California to cause cancer/birth defects or other reproductive harm. For more information go to www.P65Warnings.ca.gov

1. Welcome & Congratulations

Congratulations on your purchase of a new ALTEC AIR P1500W Series Air Dryer! We here at ALTEC AIR are very proud of our products and we are committed to providing you with the best value and service possible.

We are sure that you will be satisfied with your new air dryer and would like to thank you for choosing ALTEC AIR for your air dryer requirements. We also hope that you will continue to choose us for your future air pressure and related product purchases.

For information about this and other ALTEC AIR products, please visit us on the web at:

www.AltecAIR.com

2. Introduction

PLEASE READ THIS USER'S GUIDE THOROUGHLY AND SAVE FOR FUTURE REFERENCE.

This User's Guide is provided for the benefit of our customers and contains information and direction specific to the ALTEC AIR P1500W Series Air Dryers. Models covered include P1500W, P1500WLP, P1500WHP, P1502W, P1502WLP, and P1502WHP. This guide covers topics including safety, specifications, installation, registration, operation, testing, maintenance, replacement parts, service, and troubleshooting issues. Observation and compliance with this User's Guide will ensure the maximum life and efficiency of your air dryer.

This User's Guide should be read thoroughly prior to installing, operating, or servicing the air dryer in order to become familiar with the recommended procedures. This will minimize the possibility of personal injury or damage to the unit due to improper operation or handling.

3. Table of Contents

1. Welcome & Congratulations	3
2. Introduction	3
3. Table of Contents.....	4
4. Safety & Warning Information.....	6
5. Overview & Specifications.....	8
5.1 Product Description	8
5.2 Key Features.....	8
5.3 P1500W Series Air Dryer Models	8
5.4 Technical Specifications.....	9
5.5 Dryer Function Overview	10
6. Installing Your Dryer.....	11
6.1 Safety & Warning Information	11
6.2 Before You Begin.....	12
6.3 Included Contents	13
6.4 Required Tools and Materials.....	13
6.5 Installation Steps.....	14
6.6 Installation Checklist	22
7. Registering Your Dryer.....	23
8. Operating Your Dryer	24
8.1 Safety & Warning Information	24
8.2 Front Panel Display	25
8.3 Identifying Dryer Alarms	26
8.4 Accessing the Setup Menu.....	29
8.5 Using the System Setup Menu.....	29
8.6 Using the Alarm Setup Menu	35
8.7 Open Front Panel.....	44
8.8 Depressurizing the Dryer.....	44
8.9 Connecting to Common Alarm Terminals	44
8.10 Connecting to Power Fail Alarm Terminals.....	45
8.11 Connecting via Web Browser	45
8.12 Using the Web Interface	48
8.13 Updatinge Firmware	51
8.14 Secure Mode	51
8.15 Certificate Management.....	55
8.16 Connecting via SNMP	58
9. Testing Your Dryer	59
9.1 Safety & Warning Information	59
9.2 Measuring Compressor Amp Draw	60
9.3 Measuring Compressor Voltage	61
9.4 Measuring Incoming Voltage	62
9.5 Measuring Voltages at Solid State Relay	63
9.6 Testing Consistent Heatless Dryer Cycling.....	65
9.7 Testing Unloader Valve.....	66
9.8 Measuring Heatless Dryer Solenoid Voltage.....	67
9.9 Testing Air Dryer Fan.....	68
9.10 Testing Safety Relief Valve.....	69
9.11 Testing Compressor ON/OFF Cycling	69
9.12 Testing High Compressor Last Run Time Alarm.....	70
9.13 Testing Humidity Alarm and System Shutdown	71
9.14 Testing High Outlet Pressure Alarm....	73
9.15 Testing Low Outlet Pressure Alarm....	75
9.16 Testing Air Fittings & Hoses for Leaks	76
10. Maintaining Your Dryer	77
10.1 Safety & Warning Information	78
10.2 Six Month Maintenance.....	80

10.3 8,000 Hour Maintenance	81	13.14 Compressor Doesn't Operate	93
11. Replacement Parts & Accessories	82	13.15 Compressor Won't Build Pressure.....	93
11.1 Dryer Parts.....	82	13.16 Compressor Excessive AMP Draw....	94
11.2 Dryer Parts cont.	83	13.17 High Compressor Last Run Time	
11.3 Heatless Dryer Assembly Parts.....	84	Alarm	94
11.4 Accessories for Your Dryer	85	13.18 Can't Create a High Compressor Last	
11.5 Ordering Parts from ALTEC AIR	85	Run Time Alarm	95
12. Service & Repair.....	86	13.19 Compressor Rapid ON/OFF Cycling .	95
12.1 Services Offered	86	13.20 Contacting ALTEC AIR Technical	
12.2 Initiating a Service Transaction	86	Support.....	96
13. Troubleshooting Your Dryer.....	87	14. Appendix	97
13.1 Before You Call ALTEC AIR	87	14.1 Wiring Diagram	97
13.2 Safety & Warning Information.....	87	14.2 Set Point Limits and Defaults	98
13.3 Air Dryer Won't Power ON.....	88	14.3 SNMP Parameters.....	99
13.4 Display Screen Not Functioning.....	89	15. Limited Warranty Agreement.....	100
13.5 High Outlet Pressure Alarm.....	89	Registration Reminder	100
13.6 Can't Create a High-Pressure Alarm ...	89	16. Contacting ALTEC AIR	101
13.7 Low Outlet Pressure Alarm	90	16.1 General.....	101
13.8 Can't Create a Low-Pressure Alarm	90	16.2 Sales.....	101
13.9 High Humidity.....	91	16.3 Service	101
13.10 Can't Create a High Humidity Alarm /		16.4 Technical Support.....	101
Shutdown.....	92	17. Notes.....	102
13.11 High Flow Rate Alarm.....	92		
13.12 High Cabinet Temperature Alarm	92		
13.13 Inconsistent Heatless Dryer Cycling..	93		

4. Safety & Warning Information

This section contains general information about safety and warning points to consider and adhere to during installation, operation, and maintenance of your air dryer. PLEASE READ THIS SECTION BEFORE PERFORMING ANY OPERATION OR PROCEDURE ON YOUR AIR DRYER.

Additional warnings specific to an operation or procedure will also be presented throughout the following sections. These will include the  symbol as well as a label of “**WARNING!**”, “**CAUTION!**”, or “**IMPORTANT!**” Please be sure to pay close attention for these warnings and read them as you encounter them.



WARNING!

For your safety, all the information in this User's Guide must be followed to minimize the risk of electrical shock and prevent property damage or personal injury.



WARNING!

Extreme care should be exercised to avoid contact with live electrical circuits. Many procedures performed during installation, operation, testing, and maintenance of this air dryer require the equipment to be running, creating a situation for potential electrical shock. It is highly recommended that you remove all jewelry before performing any procedures.



WARNING!

Internal surfaces may be hot. Use care when coming into contact with internal components as there is a potential for some of these components to become hot when in operation or standby.



WARNING!

High Noise. ALTEC AIR air dryers are meant to be installed in an unattended area.

**CAUTION!**

Depressurizing the air dryer may be necessary before performing certain procedures. **NEVER** remove pressure sensing tubes from the Control Board without depressurizing the air dryer first, or **damage to the Control Board will occur.**

**CAUTION!**

Incoming power to dryer must be:

- 15-amp service recommended
- 110 - 125 VAC, 50/60 Hz for P1500W, P1500WLP & P1500WHP models
- 208 - 230 VAC, 50/60 Hz, 1 Phase for P1502W, P1502WLP & P1502WHP models

**IMPORTANT!**

Performing routine maintenance as outlined in the *Maintaining Your Dryer* section will ensure optimal performance over the lifecycle of your air dryer.

**IMPORTANT!**

Performing procedures not described in this User's Guide or installing components not supplied by ALTEC AIR is **NOT RECOMMENDED AND MAY VOID THE WARRANTY.**

**CAUTION!**

This Air Dryer does not contain an internal Surge Protection Device (SPD). If an SPD is required, it must be supplied by the user.

**IMPORTANT!**

Installation of ALTEC AIR air dryers are intended for network telecommunication facilities (non-customer premises) only.

5. Overview & Specifications

5.1 Product Description

The P1500W Series Air Dryers from ALTEC AIR are designed to intake wet ambient air and remove the moisture for delivery to applications requiring a constant, on-demand source of dry, pressurized air. This process is fully automatic and will remain consistent with minimal required periodic maintenance. These dryers are designed specifically for indoor use. The P1500W Series Air Dryers employ a fully digital operating platform offering the most accurate readings of dryer variables, removable access panel allowing easier access for adjustment and maintenance, and ultra-quiet Compressor with an industry leading maintenance interval of 8,000 hours.

5.2 Key Features

- LCD display of all operating parameters
- Solid state microprocessor-based circuitry eliminates costly maintenance
- Accurate humidity sensing within $\pm 0.1\%$ RH
- Quietest dryer on the market - less than 50 dBA
- Oil-less Compressors with 8,000-hour maintenance interval

5.3 P1500W Series Air Dryer Models

Model	Description
P1500W	110 - 125 VAC, Standard Pressure 2 - 15 PSI (13.8 - 103.4 KPa)
P1500WLP	110 - 125 VAC, Low Pressure 0.30 - 7.50 PSI (2.1 - 51.7 KPa)
P1500WHP	110 - 125 VAC, High Pressure 2 - 60 PSI (13.8 - 413.7 KPa)
P1502W	208 - 230 VAC, Standard Pressure 2 - 15 PSI (13.8 - 103.4 KPa)
P1502WLP	208 - 230 VAC, Low Pressure 0.30 - 7.50 PSI (2.1 - 51.7 KPa)
P1502WHP	208 - 230 VAC, High Pressure 2 - 60 PSI (13.8 - 413.7 KPa)

5.4 Technical Specifications

	P1500W	P1500WLP	P1500WHP	P1502W	P1502WLP	P1502WHP
Output Capacity *	Normal: Up to 1200 SCFD (34 SCMD) continuous * Maximum: 1500 SCFD (42.5 SCMD) emergency *					
Power Requirements	110 - 125 VAC, 50/60 Hz, 7.0 Amps			208 – 230 VAC, 1 Phase, 50/60 Hz, 3.5 Amps		
Outlet Pressure Range	2 - 15 PSI (13.8-103.4 KPa)	0.30 - 7.50 PSI (2.1-52.7 KPa)	2 - 60 PSI (13.8-413.6 KPa)	2 - 15 PSI (13.8-103.4 KPa)	0.30 - 7.50 PSI (2.1-52.7 KPa)	2 - 60 PSI (13.8-103.4 KPa)
Outlet Air Humidity	Less than 2% RH					
Compressor Type	Two-cylinder, 3/4 HP, oil-less type					
Drying Method	Heatless Desiccant					
Operating Temperature Range	40° to 85°F (optimal) (4° to 29°C)					
Noise Level	48 dBA at 10' (3m)					
Alarms	Standard alarms – complete readings of all critical measurement points, individual alarm indication display					
Outlet Connections	3/8" O.D. tube fitting					
Dimensions	12" D x 17.25" W x 27" H (30.48cm D x 43.8cm W x 68cm H)					
Net Weight	80 lbs. (36.3 Kg)					

* **NOTE:** The Flow measurement will display ***** for flows over 1000 SCFD (28.3 SCMD) for the **P1500WHP & P1502WHP** models.

5.5 Dryer Function Overview

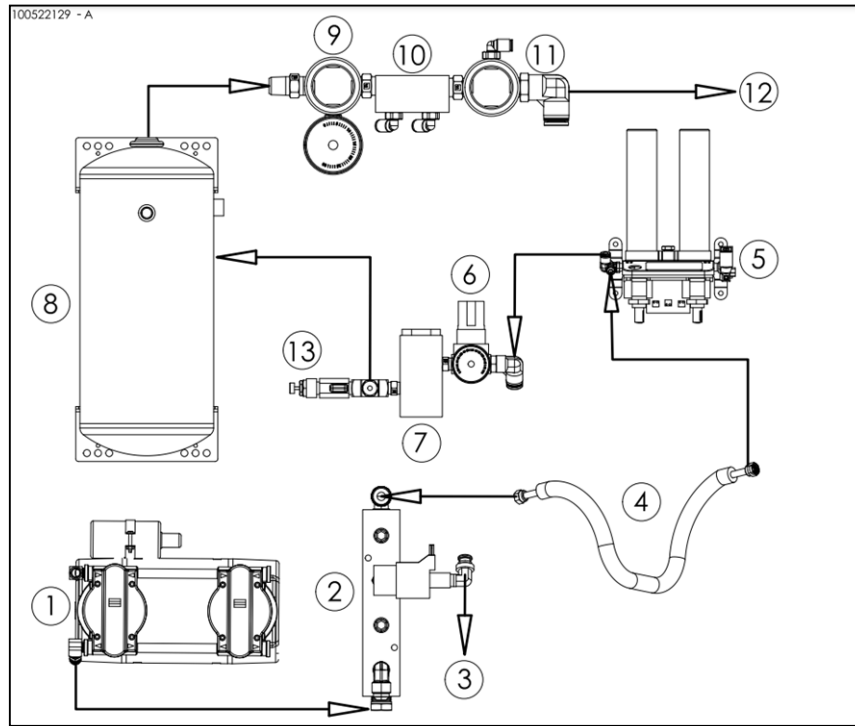

	Component	Description
1	Compressor	Compresses drawn in ambient air.
2	Unloader Valve	Relieves excess Compressor head pressure.
3	Unloader Valve Exhaust	Exhausts the air from the Unloader Valve.
4	In-Line Cooler	Cools compressed air prior to drying function.
5	Heatless Dryer	Removes moisture from compressed air.
6	Capacity Control Valve	Regulates System Pressure and prevents air from bleeding back through the Heatless Dryer.
7	Humidity Sensor	Measures the Humidity of the compressed air.
8	Air Tank	Stores dry compressed air.
9	Static Pressure Regulator	Regulates the Static Pressure (17 PSI (117.2 KPa) for W & WLP, 60 PSI (413.7 KPa) for WHP). Maintains constant pressure on the Flow Block for accurate Flow measuring.
10	Flow Block	Measures the Flow Rate of compressed air.
11	Outlet Pressure Regulator	Regulates the Outlet Pressure.
12	Pressure Outlet	Outputs the pressure set by the Outlet Pressure Regulator.
13	Adjustable Bleed Orifice	Allows user to adjust duty cycle for optimal performance based on site configuration.

6. Installing Your Dryer

6.1 Safety & Warning Information



WARNING!

Extreme care should be exercised to avoid contact with live electrical circuits. Many procedures performed during installation, operation, testing, and maintenance of this air dryer require the equipment to be running, creating a situation for potential electrical shock. It is highly recommended that you remove all jewelry before performing any procedures.



WARNING!

Internal surfaces may be hot. Use care when coming into contact with internal components as there is a potential for some of these components to become hot when in operation or standby.



CAUTION!

Proper Installation & Maintenance as outlined in this User's Guide is extremely important to ensure the reliability and longevity of the equipment as well as prevent damage or personal injury.



CAUTION!

Incoming power to dryer must be:

- 15-amp service recommended
- 110 - 125 VAC, 50/60 Hz for P1500W, P1500WLP & P1500WHP models
- 208 - 230 VAC, 50/60 Hz, 1 Phase for P1502W, P1502WLP & P1502WHP models

**WARNING!**

High Noise. ALTEC AIR air dryers are meant to be installed in an unattended area.

**IMPORTANT!**

Performing procedures not described in this User's Guide or installing components not supplied by ALTEC AIR is **NOT RECOMMENDED AND MAY VOID THE WARRANTY.**

6.2 Before You Begin

6.2.1 Carefully inspect the unit, including the shipping box as well as the air dryer, for ANY DAMAGE CAUSED BY SHIPPING. If any shipping damage is detected, it is important to file a claim with the shipping company prior to continuing the installation procedures.

6.2.2 Read the entire *Installing Your Dryer* section to familiarize yourself with the components and procedures before performing the air dryer installation.

6.2.3 Verify the installation location of the air dryer:

6.2.3.1 Well ventilated and free from abrasive dust or chemicals.

6.2.3.2 Ambient temperature is between 40° and 85°F (4.4° and 29.4°C) (optimal).

NOTE: Higher temperatures will decrease component lifespan.

6.2.3.3 Meets the following power requirements:

- 15-amp service recommended
- 110 - 125 VAC, 50/60 Hz for P1500W, P1500WLP & P1500WHP models
- 208 - 230 VAC, 50/60 Hz, 1 Phase for P1502W, P1502WLP & P1502WHP models

6.2.4 Notify the alarm center of the installation and potential for alarms during the process (as necessary).

6.3 Included Contents



- (1) P1500W Series Air Dryer
- (1) Installation Guide (not shown)

Package located inside the dryer:

- (1) 120 VAC Power Cord (for P1500W, P1500WLP & P1500WHP models)
- (1) 220 VAC Power Cord (for P1502W, P1502WLP & P1502WHP models)
- (1) User's Guide (not shown)

6.4 Required Tools and Materials

- 9/16" wrench
- Cup of soapy water
- 1-inch paint brush (recommended)
- Box cutter

6.5 Installation Steps

6.5.1 Using a box cutter remove the Dryer from box and all shipping materials.

NOTE: If ANY SHIPPING DAMAGE is detected, file a claim with the shipping company prior to continuing the installation procedures.



6.5.2 Open Front Panel locking latches and remove the Front Panel.



6.5.3 Check for loose parts, hoses, or wiring.

NOTE: If ANY SHIPPING DAMAGE is detected, file a claim with the shipping company prior to continuing the installation procedures.

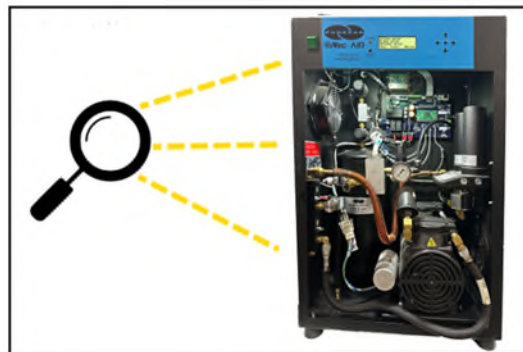

6.5.4 Remove the ship-loose contents package.



6.5.5 Remove the wooden shipping block from underneath the compressor.



6.5.6 Remove the Plug from the Outlet Port by pressing the ferrule down then pulling the plug upward.

6.5.7 Connect your Outlet Tubing directly into the dryer Outlet Port.

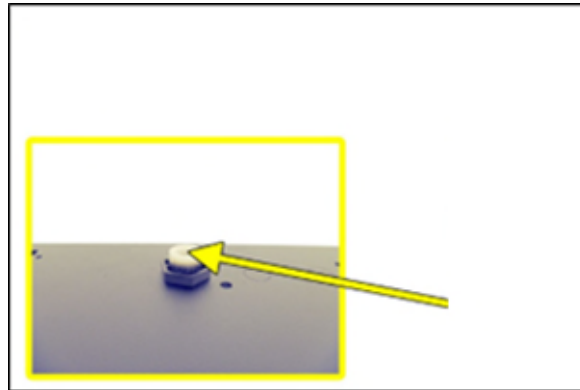

6.5.8 Place the dryer at the desired operating location:

- Place the dryer on a leveled surface
- For rack install use Universal Rack Mounting Kit P011674 (section 11.4)
- For wall install use Wall Mounting Kit P011773 (section 11.4)

6.5.9 Verify that the dryer is powered **OFF**.

6.5.10 Plug AC Power Cord to dryer.

6.5.11 Wire or plug the power cord into:

- 110 - 125 VAC power outlet for P1500W, P1500WLP & P1500WHP models.
- 208 - 230 VAC, 1 phase, power outlet for P1502W, P1502WLP & P1502WHP models.
 - Line – Black (Brown)
 - Neutral – White (Blue)
 - Ground – Green (Green/Yellow)

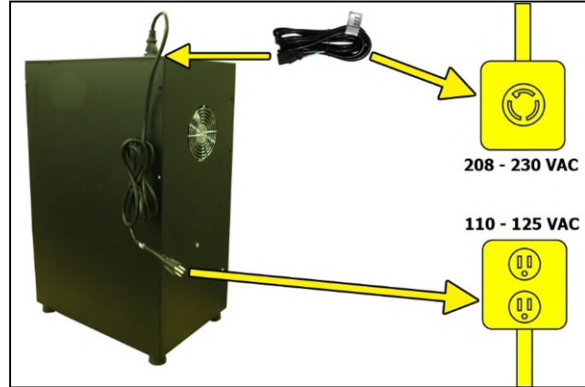

6.5.12 Power the dryer **ON**.

NOTE: The Compressor and heatless dryer will start, creating air flow through the Outlet Port.

6.5.13 Set the System Pressure:

With Compressor running:

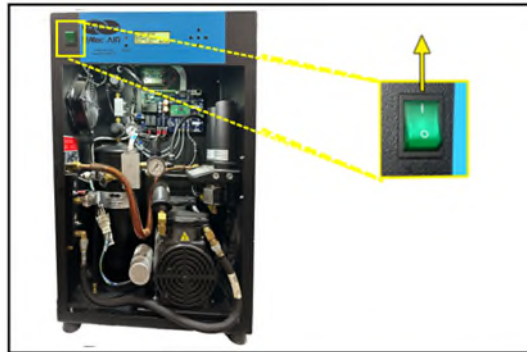

6.5.13.1 Pull the Capacity Control Valve knob out.

6.5.13.2 Turn the knob until the reading on the pressure gauge is:

80 PSI (551.6 KPa) for W & WLP

90 PSI (620.5 KPa) for WHP

NOTE: 90 PSI (620.5 KPa) may be used on W & WLP dryers in low flow applications to maintain low humidity.

6.5.13.3 Push the knob in to lock.

6.5.14 Let the dryer run until the Humidity drops below 2%

(may take up to 15 minutes). Press the **RESET** Button if the dryer goes into **SHUTDOWN** mode.

6.5.15 Power the dryer **OFF**.

6.5.16 Remove the Precision Bleed Orifice fitting from the Outlet Port by pressing the ferrule down then pulling the fitting upward.

NOTE: Save this fitting for use in low flow applications.

6.5.17 Connect the air supply line to the Outlet Port.

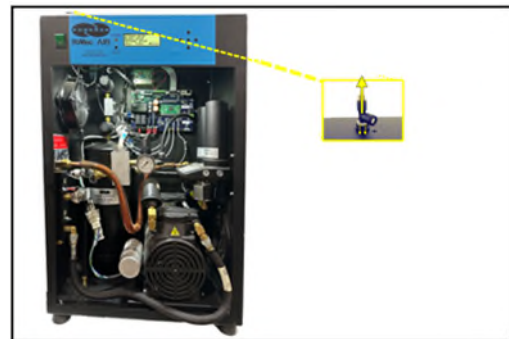
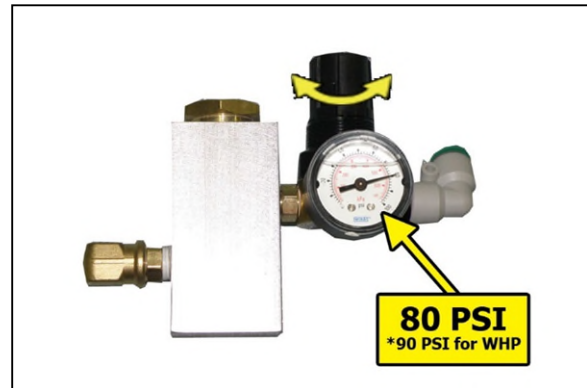
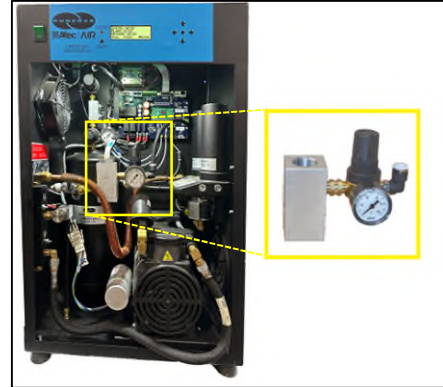

NOTE: If the downstream system is pressurized prior to installation of dryer, make reasonable attempts to install the dryer while minimizing system depressurization. Complete depressurization may result in ambient moisture being introduced into the system, which may require extended run time and dryer cycling to reduce or eliminate. Ambient moisture in the downstream system may result in high humidity alarms and shutdowns.

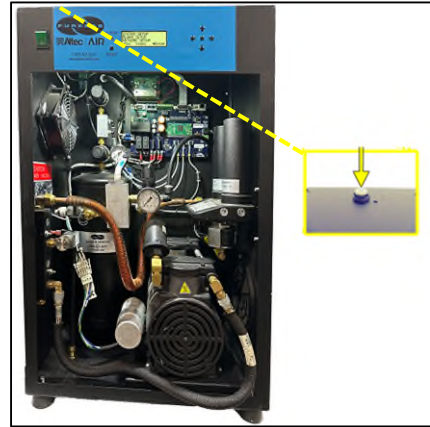

6.5.18 When connecting to a completely depressurized system, a high compressor run time alarm may be triggered. This alarm will need to be manually reset until the system is pressurized and humidity levels have reached their defined levels.

NOTE: For all dryers with minimal FLOW:

It may be necessary to enable/fine tune the Adjustable Bleed Orifice assembly to maintain a constant air flow and to prevent humidity creep due to lack of cycling.

6.5.19 By default the adjustable bleed orifice is set to 10% duty cycle and enabled from the factory but in some instances it may be necessary to adjust it higher or lower depending on your application. It has two points of adjustment. The on/off lever which enables (inline position) or disables (perpendicular position) its operation and the bleed adjustment with locknut which allows you to precisely adjust the amount of air being bled out of the tank.



6.5.20 If you're experiencing duty cycles greater than 35% we suggest lowering the amount of bleed by turning the adjustment clockwise to lower it. In some instances, it's possible that there is enough of an external leak outside the dryer where the bleed isn't needed at all and just needs to be disabled by engaging the "Off" position on the lever.

6.5.21 One thing to note is every application/site conditions will vary therefore a specific setting isn't referenced. Rather you must fine tune the dryer for your conditions. The ideal setup is to get the duty cycle as low as you can achieve while maintaining 0.0% humidity reading on the dryer at all times.

6.5.22 Once adjustments have been made allow for the dryer to run for 15 mins and monitor any trends in humidity. If the dryer is showing the humidity creeping upwards as time goes on, than increase the duty cycle time by adding more bleeding (turning counter clockwise ¼ turn per adjustment period). If the humidity is stable and dropping down towards 0.0% you can elect to leave the adjustment where it is by tightening the locknut using a 14mm socket/wrench.

6.5.23 Power the dryer ON.

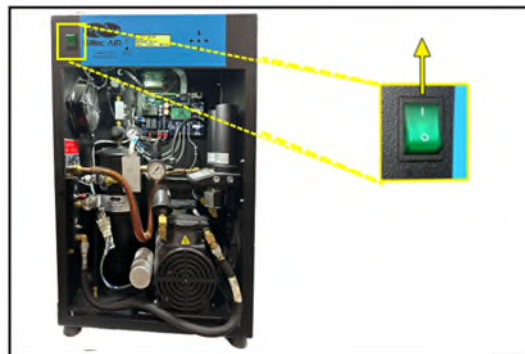

6.5.24 Set the Static Pressure:

6.5.24.1 Pull Static Pressure
Regulator knob out.

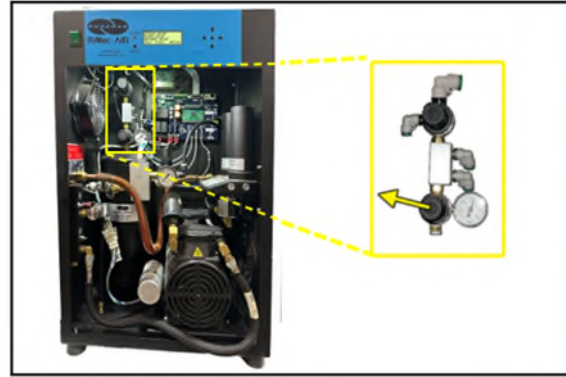

6.5.24.2 Turn knob until the
reading on the pressure
gauge is:
17 PSI (117.2 PSI) for
W & WLP
60 PSI (413.7 KPa) for
WHP

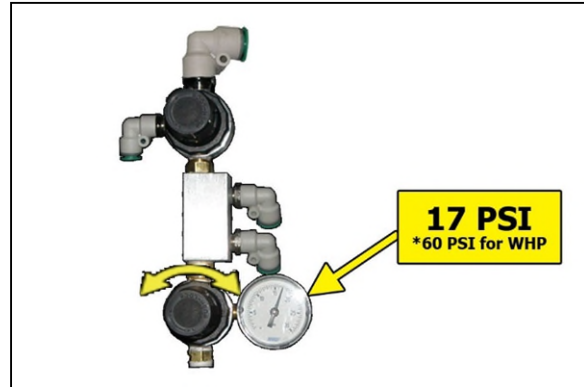

6.5.24.3 Push knob in to lock.

6.5.25 Set the Outlet Pressure:

6.5.25.1 Pull the Outlet
Pressure Regulator knob
out (or loosen the
retaining nut – LP
Models).

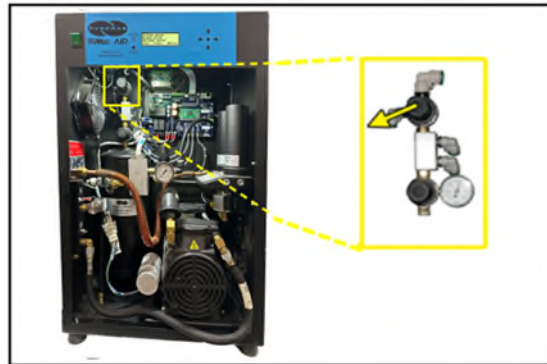

6.5.25.2 Turn knob until Outlet Pressure (**OUTP**) reading is at the desired
setting.

6.5.25.3 Push knob in to lock (or tighten the retaining nut – LP Models).

6.5.26 Check for air leaks:

NOTE: This is a general procedure that can be applied to any fitting or hose that has air pressure in it. **DO NOT SOAP TEST THE HUMIDITY SENSOR FITTING. DAMAGE TO THE SENSOR MAY OCCUR.**

With Compressor NOT running:

6.5.26.1 Listen for any 'hissing' sounds which may indicate a fitting or hose air leak.

With Compressor running:

6.5.26.2 Use a 1-inch paint brush to dab soapy water on the air fitting or hose connection to be tested.

If air bubbles appear at the connection, this indicates that air is leaking from the connection.

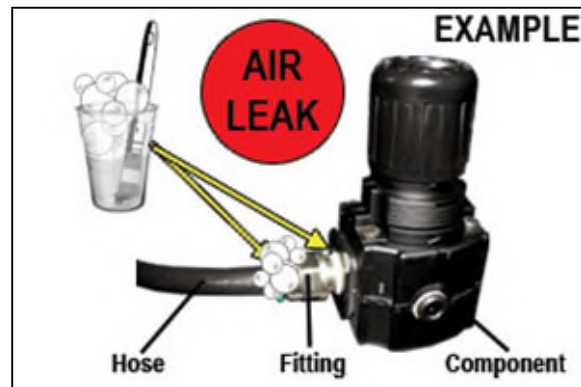

If any leaks are detected, take steps to seal them off (as necessary):

- *Tighten the fitting*
- *Re-connect loose hose*
- *Replace the fitting / hose / component*

6.5.27 It is recommended to observe the air dryer for a minimum of 30 minutes (1 hour preferred) and/or through multiple run and dwell cycles to ensure there are no issues (e.g., humidity, flow, compressor run time, etc.) which may result in alarms and/or dryer shut down.

6.5.28 Re-install the Front Panel.

6.5.29 REGISTER YOUR DRYER. *See section 7. for detail*

Note: To change Unit Settings on your dryer see section 8.4.7 for details

Note: Contact Altec AIR technical support with any questions or concerns during installation. See section 16.4

6.6 Installation Checklist

- No shipping damage was detected.
- Dryer location meets the following requirements:
 - Well ventilated
 - Free from abrasive dust or chemicals
 - Ambient temperature is between 40° and 85°F (4.4 and 29.4°C) (optimal)
- Shipping foam blocks removed from Compressor.
- System Pressure is set to:
 - 80 PSI (551.6 KPa)** for W& WLP models
 - 90 PSI (620.5 KPa)** for WHP models
- Static Pressure is set to
 - 17 PSI (117.2 KPa)** for W & WLP models
 - 60 PSI (413.7 KPa)** for WHP models
- No air leaks are present in the system.
- No alarms are present on the Display Panel.

7. Registering Your Dryer

Please take a moment to register your ALTEC AIR P1500W Series Air Dryer. Registering is necessary to activate the Limited Warranty on your product. Once you register, you are eligible to receive free technical support, as well as updates concerning your ALTEC AIR products.

Register Online at www.AltecAIR.com/registration

Or by Phone 1-800-521-5351 (**option 2**)

Have the following information available:

Model #: _____ **Serial #:** _____

Company Name: _____ **Location Name:** _____

Shipping Address: _____

City: _____ **State:** _____ **Zip Code:** _____

Contact Name: _____ **Phone #:** () - ext. _____

Email: _____

8. Operating Your Dryer

8.1 Safety & Warning Information



WARNING!

Extreme care should be exercised to avoid contact with live electrical circuits. Many procedures performed during installation, operation, testing, and maintenance of this air dryer require the equipment to be running, creating a situation for potential electrical shock. It is highly recommended that you remove all jewelry before performing any procedures.



WARNING!

Internal surfaces may be hot. Use care when coming into contact with internal components as there is a potential for some of these components to become hot when in operation or standby.



WARNING!

High Noise. ALTEC AIR air dryers are meant to be installed in an unattended area.



IMPORTANT!

Performing procedures not described in this User's Guide or installing components not supplied by ALTEC AIR is **NOT RECOMMENDED AND MAY VOID THE WARRANTY.**

8.2 Front Panel Display



CAUTION!

The Display Screen is covered by a clear protective layer that guards against Electrostatic Discharge (ESD). **DO NOT REMOVE THIS LAYER.**

8.2.1 ALARM LED – Indicates an alarm is present.

8.2.2 RESET Button – Clears an alarm and allows the system to continue operating.

8.2.3 HOLD Button – Freezes the current information screen on the display. When pressed again, it will allow the information screens to begin cycling again.

8.2.4 Arrow Buttons – Used to navigate screens and set values

8.2.5 Display Screen - Shows the current dryer readings. Will cycle between the following information screens (unless the **HOLD** button has been pressed):

8.2.5.1 Tank Screen

TANK – Air Tank pressure - fluctuates between

- **25 – 90 PSI* (172.4 – 620.5 KPa)*** for P1500W, P1500WLP, P1502W & P1502WLP models
*(50 – 90 PSI (344.7 – 620.5 KPa)

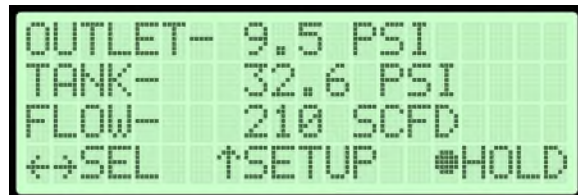

for Dryers using Firmware v2.84 and older)

- **60 – 90 PSI (413.7 – 620.5 KPa)** for P1500WHP & P1502WHP models

OUTLET – Outlet Pressure regulated by the Outlet Pressure Regulator

TANK – Air Tank pressure

FLOW – Outlet flow of the dryer

8.2.6 System Status Screen

SYS STATUS: ONLINE if dryer working normally, SHUTDOWN during temperature or humidity alarm

CABINET – Cabinet Temperature

HUMIDITY – Outlet Humidity

```
SYS STATUS- ONLINE
CABINET-      82°F
HUMIDITY-    1.5%
↔SEL  ↑SETUP  ●HOLD
```

8.3 Identifying Dryer Alarms

8.3.1 High Outlet Pressure Alarm -

Occurs when the Outlet Pressure (**OUTLET**) rises above the alarm set point for more than one (1) minute.

(Default setting is 12.0 PSI (82.7

KPa) for W models, 7.50 PSI

(51.7 KPa) for WLP models &

35.0 PSI (241.3 KPa) for WHP models)

```
OUTLET- 9.5 PSI HALR
TANK-   32.6 PSI
FLOW-   210 SCFD
↔SEL  ↑SETUP  ●HOLD
```

See section 13.5 for troubleshooting information.

8.3.2 Low Outlet Pressure Alarm –

Occurs when the Outlet Pressure (**OUTLET**) drops below the alarm set point for more than one (1)

minute. (Default setting is 6.5

PSI for W models, 0.30 PSI for

WLP models & 25.0 PSI for

WHP models)

```
OUTLET- 9.5 PSI LALR
TANK-   32.6 PSI
FLOW-   210 SCFD
↔SEL  ↑SETUP  ●HOLD
```

See section 13.7 for troubleshooting information.

8.3.3 High Flow Rate Alarm –

Occurs when the Flow Rate (**FLOW**) rises above the alarm set point for more than one (1) minute.

(Default setting is 500 SCFD
(14.2 SCMD))

```

OUTLET- 9.5 PSI
TANK- 32.6 PSI
FLOW- 528 SCFD ALR
←→SEL ↑SETUP ●HOLD
  
```

8.3.4 High Humidity Alarm –

Occurs when the Humidity level rises above the alarm set point for more than one (1) minute.

(Default setting is 10.0%)

```

SYS STATUS- SHUTDOWN
CABINET- 81°F
HUMIDITY- 15.5%ALR
←→SEL ↑SETUP ●HOLD
  
```

If this alarm is present for one (1) minute or more, the air Dryer will go into **SHUTDOWN** mode to prevent saturated air from being delivered to the supply line.

See section 13.9 for troubleshooting information.

8.3.5 High Cabinet Temperature Alarm -

Occurs when the temperature in the cabinet rises above 120°F (48.9°C) for more than ten (10) seconds.

If this alarm is present for three
(3) minutes or more, the

Compressor will **SHUTDOWN** to protect against damage due to overheating. Once the temperature lowers to 112°F (44.4°C) the Compressor will re-start.

```

SYS STATUS- SHUTDOWN
CABINET- 125°F ALR
HUMIDITY- 15.5%
←→SEL ↑SETUP ●HOLD
  
```

See section 13.12 for troubleshooting information.

8.3.6 High Compressor Last Run Time Alarm –

Occurs when the compressor
takes longer to pressurize the air

```

DUTY CYCLE- 0%
LAST- 03:15 MIN ALR
TOTAL- 800 HRS
←→SEL ↑SETUP ●HOLD
  
```

tank than the set point for the alarm. (Default setting is 3:00 minutes)

See section 13.17 for troubleshooting information.

8.3.7 Compressor Total Hour Alarm –

Occurs when the compressor has reached an 8,000-hour maintenance interval. Perform the required maintenance.

See section 10.3 for maintenance information.

```
DUTY CYCLE- 0%
LAST- 02:15 MIN
TOTAL- 8002 HRS ALR
←→SEL ↑SETUP ●HOLD
```

8.4 Accessing the Setup Menu

The P1500W has three (3) Setup sections:

- **System Setup** – Used to set specific values for the system.
- **Alarm Setup**– Used to set the alarm thresholds for specific readings. Once the threshold is reached (or exceeded) this results in an alarm. Each of these thresholds is factory programmed with a default value. Many of can be modified to levels based upon your specific application.
- **Network Setup** – Used to configure network settings including the IP Address, Subnet Mask, Gateway Address, and Keyword.

NOTE: Reference Appendix Section 14.2 for Limits, Defaults, and Formats.

8.4.1 Press the Up (↑) Arrow Button to access the Setup Menu.

```
SYSTEM 1 : ONLINE
HUMIDITY- 1.9%
DUTY CYCLE- 29%
←→SEL ↑SETUP ●HOLD
```

8.4.2 Press the Up (↑) & Down (↓) Arrow Buttons to Select the required menu option.

```
SYSTEM SETUP
ALARM SETUP
NETWORK SETUP
←ESC ↑↓SEL ●ENTER
```

- 8.4.3** Press the Enter (●) Button to access the menu selected or press the Left (←) Arrow Button to Escape to the information screens.

8.5 Using the System Setup Menu

In the Setup Menu:

- 8.5.1** Press the Up (↑) & Down (↓) Arrow Buttons to Select the “S” in System Setup.

- 8.5.2** Press the Enter (●) Button to access System Setup.



```

SYSTEM SETUP
ALARM SETUP
NETWORK SETUP
←ESC  ↑↓SEL  ●ENTER
  
```

- 8.5.3 Set Alarm Delay** (default setting is ON) –

- 8.5.3.1** Press the Enter (●) Button to access the edit screen.



```

SET ALARM DELAY
OFF
←Esc  ↑↓Scroll  ●Enter
  
```

- 8.5.3.2** Press the Up & Down Arrow Buttons to Select the correct choice (On or Off).

- 8.5.3.3** Press the Enter (●) Button to submit the selection.



```

SET ALARM DELAY
OFF
      ↑↓Sel  ●Enter
  
```

- 8.5.3.4** Press the Left (←) & Right (→) Arrow Buttons to Select the correct choice (Yes or No).



```

SET ALARM DELAY
OFF
ARE YOU SURE Y N
      ↑↓Sel  ●Enter
  
```

- 8.5.3.5** Press the Enter (●) Button to confirm the selected choice. This will lock in the new setting.

8.5.4 Press the Up (↑) Arrow Button to access the next screen.

8.5.5 Set Start Up Delay (default setting is 0 seconds) –

8.5.5.1 Press the Enter (●) Button to access the edit screen.

```

SET STARTUP DELAY
  00 SECONDS
(DEFAULT= 0 SECONDS)
←Esc ↑↓Scroll #Enter
  
```

8.5.5.2 Press the Up & Down Arrow Buttons to Select the digit to change.

```

SET STARTUP DELAY
  00 SECONDS
(RANGE= 0-10)
      ↑↓Sel  #Enter
  
```

8.5.5.3 Press the Up (↑) & Down (↓) Arrow Buttons to Change the value of the selected digit.

8.5.5.4 Press the Enter (●) Button to submit the new setting.

8.5.5.5 Press the Left (←) & Right (→) Arrow Buttons to Select the correct choice (Yes or No).

```

SET STARTUP DELAY
  00 SECONDS
ARE YOU SURE Y N
      ↑↓Chg  #Enter
  
```

8.5.5.6 Press the Enter (●) Button to confirm the selected choice. This will lock in the new setting.

8.5.6 Press the Up (↑) Arrow Button to access the next screen.

8.5.7 Reset Compressor Total Time –

8.5.7.1 Press the Enter (●) Button to access the reset screen.

```

RESET SYS 1 COMP
TOTAL TIME- 3256 HRS
←Esc ↑↓Scroll #Enter
  
```

- 8.5.7.2** Press the Left (←) & Right (→) Arrow Buttons to Select the correct choice (Yes or No).

RESET SYS 1 COMP
TOTAL TIME TO 0 HRS
ARE YOU SURE Y N
#Enter

- 8.5.7.3** Press the Enter (●) Button to confirm the selected choice. This will reset the Total Time to zero (0).

- 8.5.8** Press the Up (↑) Arrow Button to access the next screen.

8.5.9 Reset to Factory Default Values –

- 8.5.9.1** Press the Enter (●) Button to access the reset screen.

RESET TO FACTORY
DEFAULT VALUES

- 8.5.9.2** Press the Left (←) & Right (→) Arrow Buttons to Select the correct choice (Yes or No).

SET CURRENT TIME
20:04
Sel←→ Chg↑↓ #Enter
ARE YOU SURE Y N
#Enter

- 8.5.9.3** Press the Enter (●) Button to confirm the selected choice. This will reset all settings to Factory Default Values

- 8.5.10** Press the Up (↑) Arrow Button to access the next screen.

8.5.11 Set Date –

- 8.5.11.1** Press the Enter (●) Button to access the edit screen.

SET CURRENT DATE
01/14/2019
←Esc ↑↓Scroll #Enter

8.5.11.2 Press the Left (←) & Right (→) Arrow Buttons to Select the digit to change.



8.5.11.3 Press the Up (↑) & Down (↓) Arrow Buttons to Change the value of the selected digit.

8.5.11.4 Press the Enter (●) Button to submit the new setting.

8.5.11.5 Press the Left (←) & Right (→) Arrow Buttons to Select the correct choice (Yes or No).



8.5.11.6 Press the Enter (●) Button to confirm the selected choice. This will lock in the new setting.

8.5.12 Set Time –

8.5.12.1 Press the Enter (●) Button to access the edit screen.



8.5.12.2 Press the Left (←) & Right (→) Arrow Buttons to Select the digit to change.



8.5.12.3 Press the Up (↑) & Down (↓) Arrow Buttons to Change the value of the selected digit.

8.5.12.4 Press the Enter (●) Button to submit the new setting.

8.5.12.5 Press the Left (←) & Right (→) Arrow Buttons to Select the correct choice (Yes or No).

```

SET CURRENT TIME
  20:04
ARE YOU SURE Y N
Sel←→ Chg↑↓ #Enter
  
```

8.5.12.6 Press the Enter (●) Button to confirm the selected choice. This will lock in the new setting.

```

FIRMWARE UPDATE
VERSION: 0.1.2
LIB      : 0.1.0
←Esc    ↑↓Sel #Update
  
```

8.5.1 Firmware Update –

8.5.1.1 Insert a USB drive containing an appropriate “.pgz” firmware file from Altec Air into the USB A port on the control board.

8.5.1.2 Press the Enter (●) Button to access the Firmware Update Screen.

```

ENTER KEYWORD
  000000
←→Sel  ↑↓Chg  #Enter
  
```

8.5.1.3 Enter the device keyword and press the Enter (●) Button to access the firmware update screen.

8.5.1.4 Select the correct file version using the Up (↑) and Down (↓) Buttons

```

SELECT A FILE
  v0.1.2
←Esc    ↑↓Sel  #Update
  
```

8.5.1.5 Press the Enter (●) button to select the file

```

SELECT A FILE
  v0.1.2
ARE YOU SURE Y N
←Esc    ↑↓Sel  #Update
  
```

8.5.1.6 Press the Left (←) & Right (→) Arrow Buttons to Select the correct choice (Yes or No) and begin the update.

8.5.2 System Units–

8.5.2.1 Press the Enter (●) Button to access the edit screen.

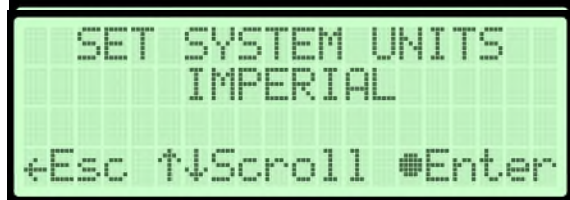

8.5.2.2 Press the Up (↑) and Down (↓) Arrow Buttons to Change the value.

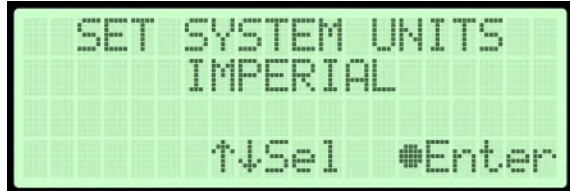

8.5.2.3 Press the Enter (●) Button to submit the new setting.

8.5.2.4 Press the Left (←) & Right (→) Arrow Buttons to Select the correct choice (Yes or No).

8.5.2.5 Press the Enter (●) Button to confirm the selected choice. This will lock in the new setting.

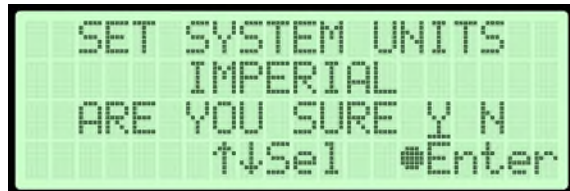

8.5.3 Set device type–

8.5.3.1 This screen allows you to set the device type, if your board is new, or the incorrect device type has been configured

8.5.3.2 Press the Enter (●) Button to access the edit screen.

8.5.3.3 Press the Up (↑) and Down (↓) Arrow Buttons to Change the value.

8.5.3.4 Press the Enter (●) Button to submit the new setting.



8.5.3.5 Press the Left (←) & Right (→) Arrow Buttons to Select the correct choice (Yes or No).

8.5.3.6 Press the Enter (●) Button to confirm the selected choice. This will reset the device and lock in the new setting.

8.6 Using the Alarm Setup Menu

In the Setup Menu:

8.6.1 Press the Up (↑) & Down (↓) Arrow Buttons to Select the “A” in Alarm Setup.



```

SYSTEM SETUP
ALARM SETUP
NETWORK SETUP
←ESC   ↑↓SEL   ●ENTER
  
```

8.6.2 Press the Enter (●) Button to access Alarm Setup.

8.6.3 Set High Humidity Threshold (default setting is 10%) –

8.6.3.1 Press the Enter (●) Button to access the edit screen.



```

SET HIGH HUMIDITY
THRESHOLD- 5.0%
(DEFAULT= 10.0%)
←Esc ↑↓Scroll ●Enter
  
```

8.6.3.2 Press the Left (←) & Right (→) Arrow Buttons to select the digit to change.



```

SET HIGH HUMIDITY
THRESHOLD- 10.0%
(RANGE= 3.0-15.0)
←→SEL   ↑↓CHG   ●ENTER
  
```

8.6.3.3 Press the Up (↑) & Down (↓) Arrow Buttons to Change the value of the selected digit.

8.6.3.4 Press the Enter (●) Button when to submit the new setting.

8.6.3.5 Press the Left (←) & Right (→) Arrow Buttons to Select the correct choice (Yes or No).

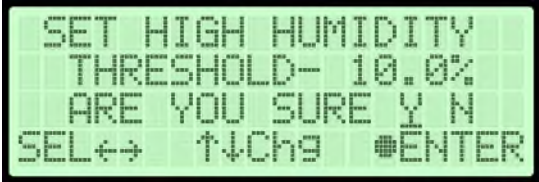

```

SET HIGH HUMIDITY
THRESHOLD- 10.0%
ARE YOU SURE Y N
SEL←→   ↑↓Chg   ●ENTER
  
```

8.6.3.6 Press the Enter (●) Button to confirm the selected choice. This will lock in the new setting.

8.6.4 Press the Up (↑) Arrow Button to access the next screen.

8.6.5 Set High Outlet Threshold (default setting is 20.00 PSI) –

8.6.5.1 Press the Enter (●) Button to access the edit screen.



SET HIGH OUTLET
THRESHOLD- 10.5 PSI
(DEFAULT= 7.5 PSI)
←ESC ↑↓SCROLL ●ENTER

8.6.5.2 Press the Left (←) & Right (→) Arrow Buttons to Select the digit to change.

8.6.5.3 Press the Up (↑) & Down (↓) Arrow Buttons to Change the value of the selected digit.

8.6.5.4 Press the Enter (●) Button when to submit the new setting.



SET HIGH OUTLET
THRESHOLD- 10.5 PSI
ARE YOU SURE Y N
←→Sel ↑↓Chg ●Enter

8.6.5.5 Press the Left (←) & Right (→) Arrow Buttons to Select the correct choice (Yes or No).

8.6.5.6 Press the Enter (●) Button to confirm the selected choice. This will lock in the new setting.

8.6.6 Press the Up (↑) Arrow Button to access the next screen.

8.6.7 Set Low Pressure Threshold (default setting is 0.30 PSI) –

8.6.7.1 Press the Enter (●) Button to access the edit screen.

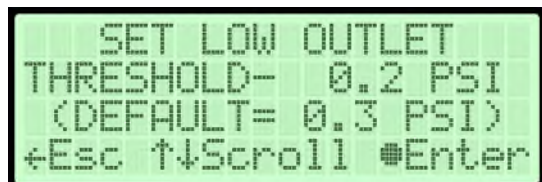

SET LOW OUTLET
THRESHOLD- 0.2 PSI
(DEFAULT= 0.3 PSI)
←Esc ↑↓Scroll ●Enter

8.6.7.2 Press the Left (←) & Right (→) Arrow Buttons to Select the digit to change.

8.6.7.3 Press the Up (↑) & Down (↓) Arrow Buttons to Change the value of the selected digit.

8.6.7.4 Press the Enter (●) Button when to submit the new setting.

8.6.7.5 Press the Left (←) & Right (→) Arrow Buttons to Select the correct choice (Yes or No).

8.6.7.6 Press the Enter (●) Button to confirm the selected choice. This will lock in the new setting.

8.6.8 Press the Up (↑) Arrow Button to access the next screen.

8.6.9 Set High Flow Threshold (default setting is 500 SCFD)

8.6.9.1 Press the Enter (●) Button to access the edit screen.

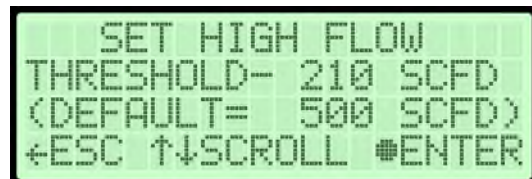

SET HIGH FLOW
THRESHOLD- 210 SCFD
(DEFAULT= 500 SCFD)
←ESC ↑↓SCROLL #ENTER

8.6.9.2 Press the Left (←) & Right (→) Arrow Buttons to Select the digit to change.

8.6.9.3 Press the Up (↑) & Down (↓) Arrow Buttons to Change the value of the selected digit.

8.6.9.4 Press the Enter (●) Button when to submit the new setting.

8.6.9.5 Press the Left (←) & Right (→) Arrow Buttons to Select the correct choice (Yes or No).

8.6.9.6 Press the Enter (●) Button to confirm the selected choice. This will lock in the new setting.

8.6.10 Press the Up (↑) Arrow Button to access the next screen.

8.6.11 Set High Duty Cycle (default setting is 70%)

8.6.11.1 Press the Enter (●) Button to access the edit screen.



```

SET HIGH DUTY CYCLE
  THRESHOLD- 70%
  (DEFAULT= 70%)
←ESC ↑↓SCROLL ●ENTER
  
```

8.6.11.2 Press the Left (←) & Right (→) Arrow Buttons to Select the digit to change.

8.6.11.3 Press the Up (↑) & Down (↓) Arrow Buttons to Change the value of the selected digit.

8.6.11.4 Press the Enter (●) Button when to submit the new setting.

8.6.11.5 Press the Left (←) & Right (→) Arrow Buttons to Select the correct choice (Yes or No).

8.6.12 Press the Up (↑) Arrow Button to access the next screen.

In the Setup Menu:

8.6.13 Press the Up (↑) & Down (↓) Arrow Buttons to Select the "N" in Network Setup.

8.6.13.1 Press the Enter (●) Button to access Network Setup.



```

SYSTEM SETUP
ALARM SETUP
NETWORK SETUP
←ESC ↑↓SEL ●ENTER
  
```

8.6.14 Enter Keyword (default Keyword is 123456) –

8.6.14.1 Press the Left (←) & Right (→) Arrow Buttons to Select the digit to change.



8.6.14.2 Press the Up (↑) & Down (↓) Arrow Buttons to Change the value of the selected digit.

8.6.14.3 Press the Enter (●) Button to submit the Keyword.

8.6.15 Set IP Address (default is 192.168.1.102) –

8.6.15.1 Press the Enter (●) Button to access the edit screen.

8.6.15.2 Press the Left (←) & Right (→) Arrow Buttons to Select the digit to change.



8.6.15.3 Press the Up (↑) & Down (↓) Arrow Buttons to Change the value of the selected digit.



8.6.15.4 Press the Enter (●) Button when to submit the new setting.

8.6.15.5 Press the Left (←) & Right (→) Arrow Buttons to Select the correct choice (Yes or No).

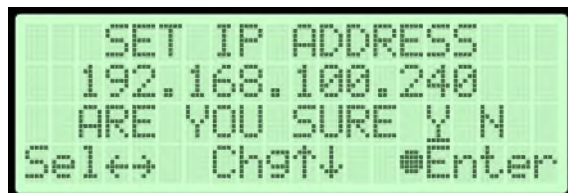

8.6.15.6 Press the Enter (●) Button to confirm the selected choice. This will lock in the new setting.

8.6.16 Set Subnet Mask (default is 255.255.255.000) –

8.6.16.1 Press the Enter (●) Button to access the edit screen.



8.6.16.2 Press the Left (←) & Right (→) Arrow Buttons to Select the digit to change.

8.6.16.3 Press the Up (↑) & Down (↓) Arrow Buttons to Change the value of the selected digit.



8.6.16.4 Press the Enter (●) Button when to submit the new setting.

8.6.16.5 Press the Left (←) & Right (→) Arrow Buttons to Select the correct choice (Yes or No).

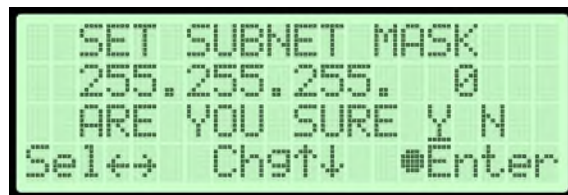

8.6.16.6 Press the Enter (●) Button to confirm the selected choice. This will lock in the new setting.

8.6.17 Set Gateway Address (default is 000.000.000.000) –

8.6.17.1 Press the Enter (●) Button to access the edit screen.

8.6.17.2 Press the Left (←) & Right (→) Arrow Buttons to Select the digit to change.

```
SET GATEWAY ADDRESS
 192.100.240 11
←Esc ↑↓Scroll #Enter
```

8.6.17.3 Press the Up (↑) & Down (↓) Arrow Buttons to Change the value of the selected digit.

```
SET GATEWAY ADDRESS
 192.168.100. 11
Sel←→ Chg↑↓ #Enter
```

8.6.17.4 Press the Enter (●) Button when to submit the new setting.

8.6.17.5 Press the Left (←) & Right (→) Arrow Buttons to Select the correct choice (Yes or No).

```
SET GATEWAY ADDRESS
 192.100.240 11
 ARE YOU SURE Y N
←→Sel ↑↓Chg #Enter
```

8.6.17.6 Press the Enter (●) Button to confirm the selected choice. This will lock in the new setting.

8.6.18 Set SNMP Trap Server (default is 000.000.000.000) –

8.6.18.1 Press the Enter (●) Button to access the edit screen.

8.6.18.2 Press the Left (←) & Right (→) Arrow Buttons to Select the digit to change.

```
SET SNMP TRAP SERVER
 192.168.100.211
←Esc ↑↓Scroll #Enter
```

```
SET SNMP TRAP SERVER
 192.168.100.211
←→Sel ↑↓Chg #Enter
```

8.6.18.3 Press the Up (↑) & Down (↓) Arrow Buttons to Change the value of the selected digit.

8.6.18.4 Press the Enter (●) Button when to submit the new setting.



```

SET SNMP TRAP SERVER
  192.168.100.211
  ARE YOU SURE Y N
←→Sel ↑↓Chg ●Enter
  
```

8.6.18.5 Press the Left (←) & Right (→) Arrow Buttons to Select the correct choice (Yes or No).

8.6.18.6 Press the Enter (●) Button to confirm the selected choice. This will lock in the new setting.

8.6.19 Change Keyword (default is 123456) –

8.6.19.1 Press the Enter (●) Button to access the edit screen.

8.6.19.2 Press the Left (←) & Right (→) Arrow Buttons to Select the digit to change.

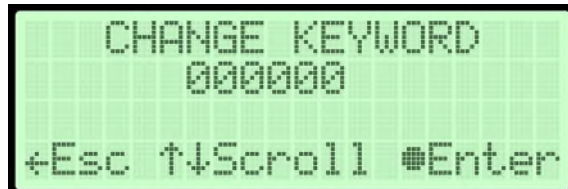

```

CHANGE KEYWORD
  000000
←Esc ↑↓Scroll ●Enter
  
```

8.6.19.3 Press the Up (↑) & Down (↓) Arrow Buttons to Change the value of the selected digit.



```

CHANGE KEYWORD
  000000
←→Sel ↑↓Chg ●Enter
  
```

8.6.19.4 Press the Enter (●) Button when to submit the new setting.

8.6.19.5 Press the Left (←) & Right (→) Arrow Buttons to Select the correct choice (Yes or No).



8.6.19.6 Press the Enter (●) Button to confirm the selected choice. This will lock in the new settings

8.6.20 Set Monitoring System Address (default is 0) –

8.6.20.1 Press the Enter (●) Button to access the edit screen.

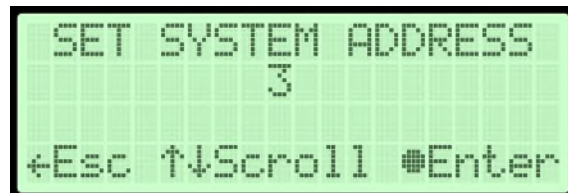

8.6.20.2 Press the Up (↑) & Down (↓) Arrow Buttons to Change the value

8.6.20.3 Press the Enter (●) Button when to submit the new setting.

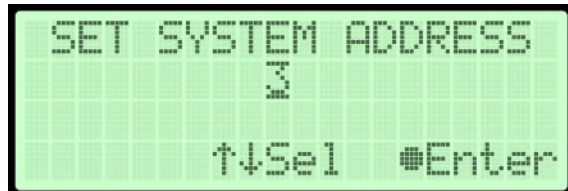

8.6.20.4 Press the Left (←) & Right (→) Arrow Buttons to Select the correct choice (Yes or No).

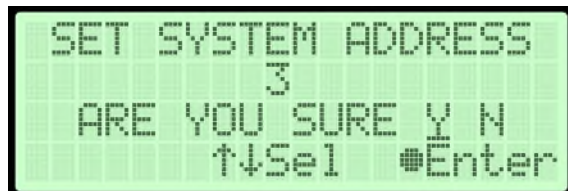

8.6.20.5 Press the Enter (●) Button to confirm the selected choice. This will lock in the new setting.

8.6.21 View MAC address

- 8.6.21.1** The device MAC address can be viewed from the network setup menu



8.7 Open Front Panel

- 8.7.1** Open Front Panel locking latches and remove the Front Panel.

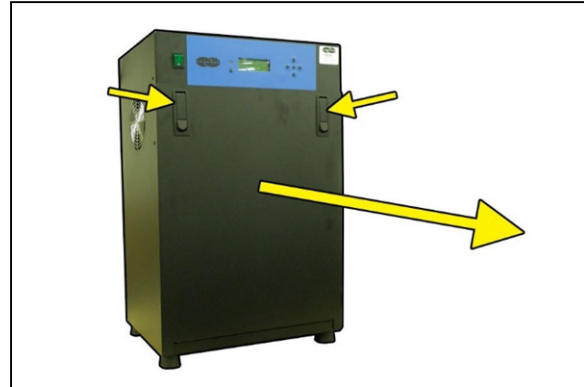

8.8 Depressurizing the Dryer

- 8.8.1** Open Front Panel (section 8.7).

- 8.8.2** Pull the ring handle on the Safety Relief Valve until all the air pressure is released.

- 8.8.3** To prevent pressure from building back up, power the dryer **OFF**

- 8.8.4** Close Front Panel.

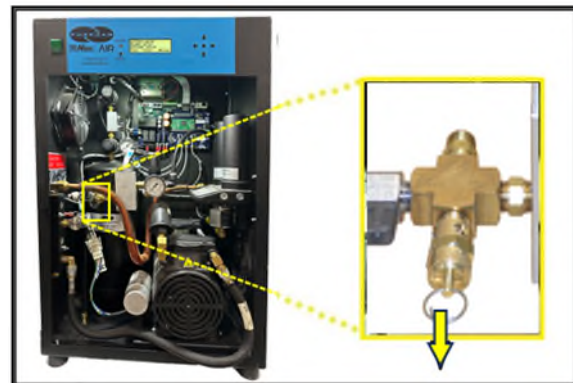

8.9 Connecting to Common Alarm Terminals

- 8.9.1** Locate the external Common Alarm pins on the Control Board

- 8.9.2** Wire the Common Alarm wire pair to the Control Board as required:

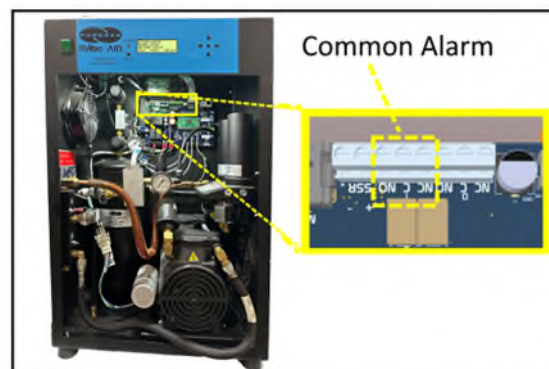

- **COMMON & NO** for CLOSE ON ALARM operation.
- **NC & COMMON** for OPEN ON ALARM operation.

8.9.3 Close Panel.

8.10 Connecting to Power Fail Alarm Terminals

8.10.1 Open Panel

8.10.2 Locate the external Power Fail pins on the Control Board.

8.10.3 Wire the Power Fail Alarm wire pair to the Control Board as required:

- **PWR FAIL & NC** for CLOSE ON ALARM operation.
- **NO & PWR FAIL** for OPEN ON ALARM operation

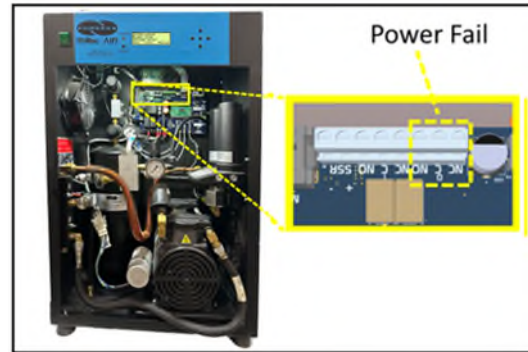

8.10.4 Close Panel.

8.11 Connecting via Web Browser

For Remote Air Dryer Monitoring Via An IP Network:

- The Air Dryer and Laptop/PC must be configured with a valid IP Address, and share the same Subnet Mask, and Gateway Address for the network.
- Use Google Chrome Web Browser.

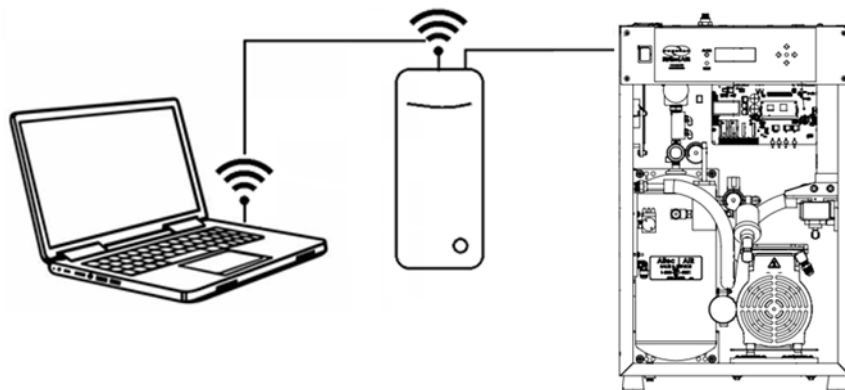

To Direct Connect A Laptop To The Dryer:

- Connect ethernet cord from laptop to dryer and verify LED's on the back of the Control Board are blinking.

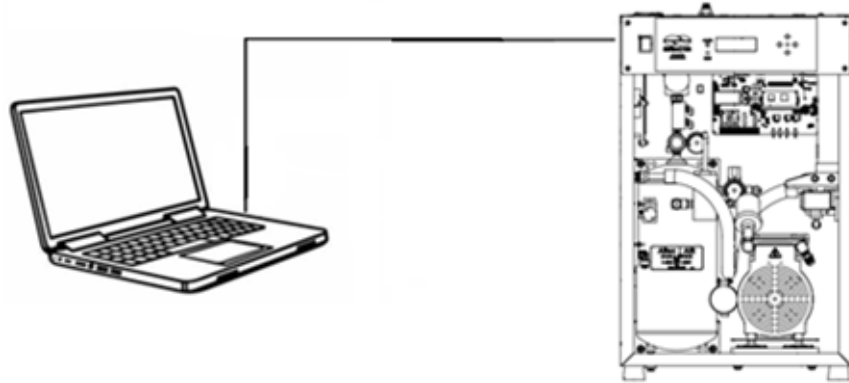

- Configure laptops ethernet port by following the steps below.
 1. In windows search bar type “Network Status” and open the application.
 2. On the left hand side under the Network & Internet section click “Ethernet”, than under Related Settings click “Change Adapter Settings”.

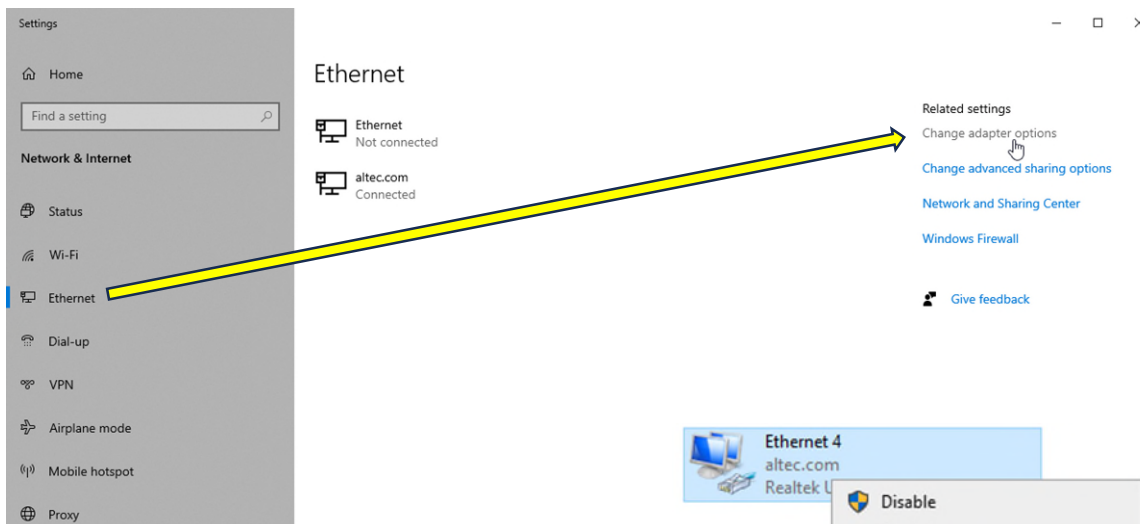

3. Select your ethernet port then right click and select properties.

4. Locate the Internet Protocol Version 4 (TCP/IP4) and double click it to open or select the “Properties” button.

5. Next check the button labeled “Use the following IP address:”. Then enter the following criteria.

- IP Address: 192.168.1.100
- Subnet Mask: 255.255.255.0
- Default Gateway: 192.168.1.1

**Note for dryers with different IP addresses, the entries will need to match the network settings that the dryer is on. Alternatively, you can set the dryer's IP address to 192.168.1.102, Gateway to 192.168.1.1, and Subnet Mask to 255.255.255.0 for the settings referenced above to work.*

6. Click “Ok” when complete on all open windows to save the settings. Note if closed without hitting “OK” the changes won't take effect.
7. Next using your Google Chrome browser type the IP address of your dryer into the URL field and hit “Enter” to access the web interface screen.

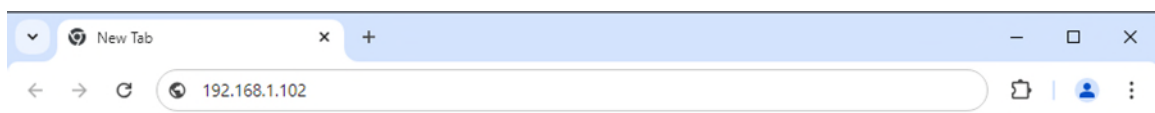
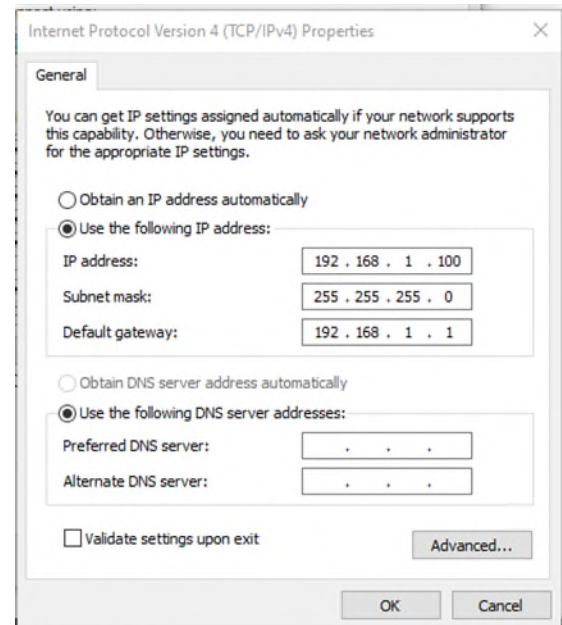
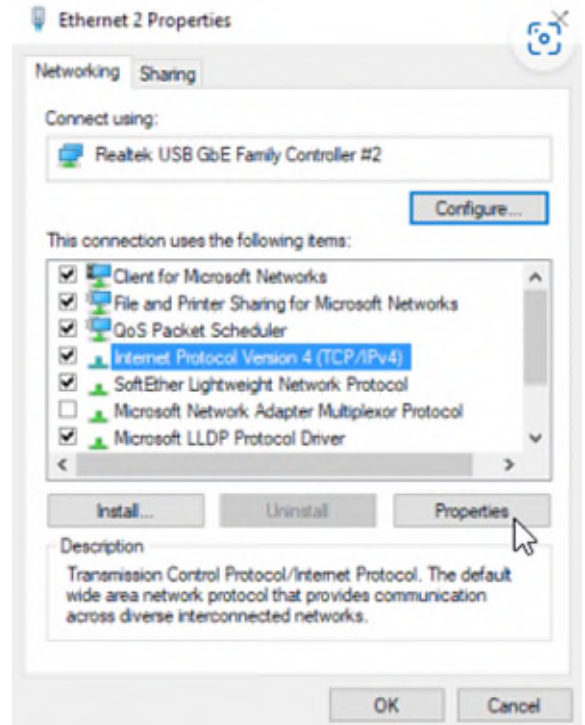

8.12 Using the Web Interface

The Web Interface is designed to be user friendly with a point and click type of navigation. It has 4 different display screens that showcase the dryer status, setup parameters, event logs, and hardware health. To make changes to the configurable parameters (orange sections) simply unlock the system by clicking on the lock icon on the top right of the screen and enter in the dryer's **keyword** (default: 123456). Once completed simply click the sections you wish to change and make the update.

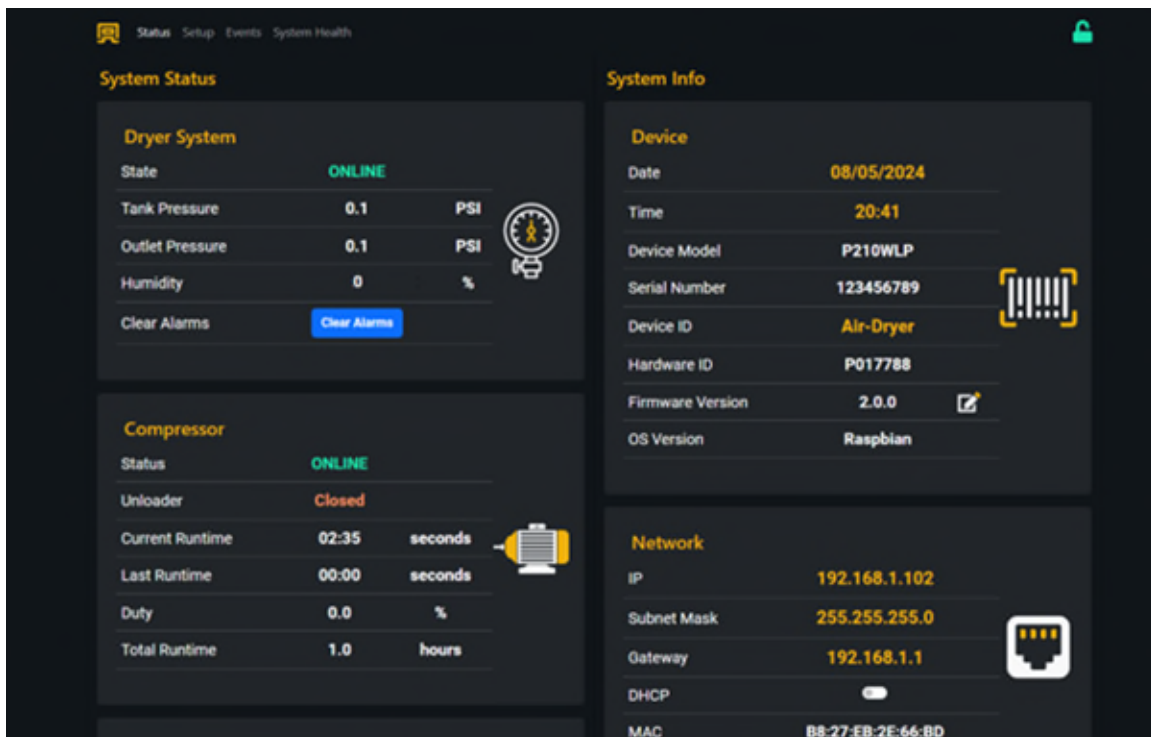

Status Setup Events System Health

Setup

System Settings

Description	Min	Max	Value	Unit
Compressor Startup Delay	0.0	10.0	0.0	sec
Startup Alarm Mask Length	120.0	3600.0	0.0	sec
Monitoring Address	0	15	0	
Alarm Delay Enable				<input checked="" type="checkbox"/>
Backlight Dim Enabled				<input type="checkbox"/>
Metric Units				<input type="checkbox"/>

Alarm Thresholds

Description	Default	Min	Max	Value	Unit
High Outlet Pressure	7.5	0.3	7.5	7.5	PSI
Low Outlet Pressure	0.3	0.3	7.5	0.3	PSI
High Humidity	10.0	3.0	15.0	10.0	%
High Duty Cycle	70.0	0.0	99.0	70.0	%
High Compressor Last Runtime	300.0	120.0	600.0	300.0	seconds

Network

IP	10.50.137.184
Subnet Mask	255.255.255.224
Gateway	10.50.137.161
DHCP	<input checked="" type="checkbox"/>
MAC	B8:27:EB:9E:6E:EB

SNMP

SNMP Trap Address 1	0.0.0.0
SNMP Trap Address 2	0.0.0.0
SNMP Trap Address 3	0.0.0.0
SNMP Trap Address 4	0.0.0.0

Status Setup Events System Health

Events Log

Filter By Type

Alarms Parameter Change Info

CSV

Alarm	Low Outlet Pressure Alarm	8/6/2024, 7:34:52 PM
Info	Alarms Reset	8/6/2024, 7:32:51 PM
Alarm	Low Outlet Pressure Alarm	8/6/2024, 7:28:41 PM
Info	Alarms Reset	8/6/2024, 7:26:40 PM
Parameter Change	Emulation Enabled	8/6/2024, 7:20:46 PM
Alarm	High Humidity SYS 01 Alarm	8/6/2024, 7:20:37 PM
Alarm	Low Outlet Pressure Alarm	8/6/2024, 7:20:37 PM
Info	Alarms Reset	8/6/2024, 7:19:03 PM
Info	Alarms Reset	8/6/2024, 7:18:36 PM
Parameter Change	Serial Number Changed from "000000000" to "123456789"	8/5/2024, 7:07:36 PM
Alarm	High Humidity SYS 01 Alarm	8/2/2024, 7:52:19 PM
Alarm	Low Outlet Pressure Alarm	8/2/2024, 7:52:19 PM
Info	Unit Power On (Firmware: 2.0.0 Library: 0.1.6)	8/2/2024, 7:50:16 PM
Info	Unit Power On (Firmware: 2.1.0 Library: 0.1.6)	8/2/2024, 7:47:55 PM
Alarm	High Humidity SYS 01 Alarm	8/2/2024, 7:45:19 PM

Status Setup Events System Health

Hardware Health

Sensor Status

Tank Pressure	0.1	PSI
Outlet Pressure	0.1	PSI
Humidity	0	%
Temperature	71.7	F

Cycle Kit

Connected **No Connection**

Last Tx

Last Rx

Monitoring

Connected **No Connection**

Last Tx

Last Rx

Software Health

Threads

Compressor Controller	RUNNING	95:54:16
Alarm Controller	RUNNING	95:54:16
Interface Thread	RUNNING	78:11:15
Heater Controller	RUNNING	95:54:16
Fan Controller	RUNNING	95:54:16
Web Thread	RUNNING	95:54:05
SNMP Thread	RUNNING	95:54:40
Serial Thread	RUNNING	95:50:27
Alarm Hardware Controller	RUNNING	95:54:15

Services

Sensor Server **active**

8.13 Updating Firmware

1. After downloading the correct firmware from www.AltecAIR.com simply click the write icon next to the current version of firmware than select “Choose File”.
2. Pick the firmware file and click “OK” to begin the upload to the dryer.

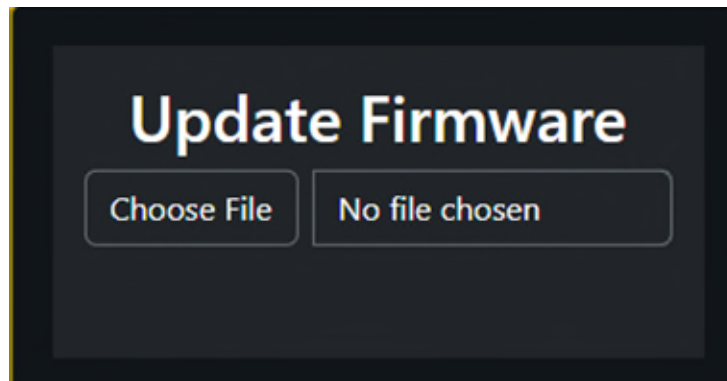
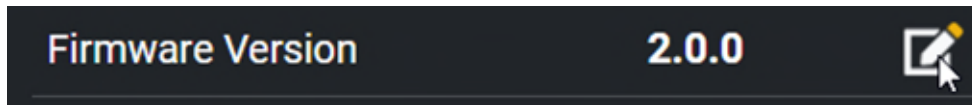

8.14 Secure Mode

Secure Mode provides enhanced security for your Altec AIR device by implementing:

- User authentication with password protection
- HTTPS encrypted communication
- Certificate-based security
- Protection against unauthorized access

Notes: Secure mode can be enabled/disabled via the front panel LCD or the web browser interface. If you forget your password the only way to disable secure mode is to physically turn it off on the dryer itself

8.14.1 Enabling Secure Mode Via LCD

8.14.1.1 Navigate to the Network Setup Menu listed in step 8.9.

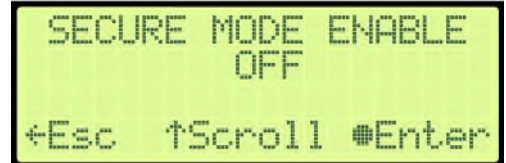

8.14.1.2 Scroll down to “Secure Mode” and Press the Enter (●) Button to access the edit screen.



8.14.1.3 Press the Up (↑) & Down (↓) Arrow Buttons to Select On/Off and Press the Enter (●) Button to make it take effect.

8.14.2 Enabling Secure Mode Via Web Browser Interface

8.14.2.1 Scroll down and click the secure protocols toggle switch to turn on secure mode.

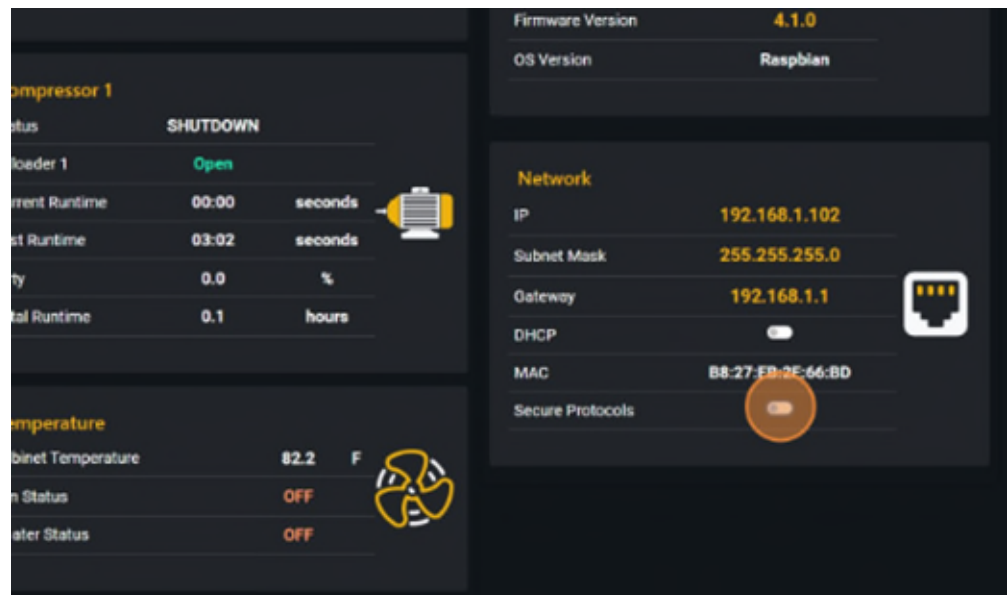

8.14.2.2 Refresh the page and you should be presented with this login screen.

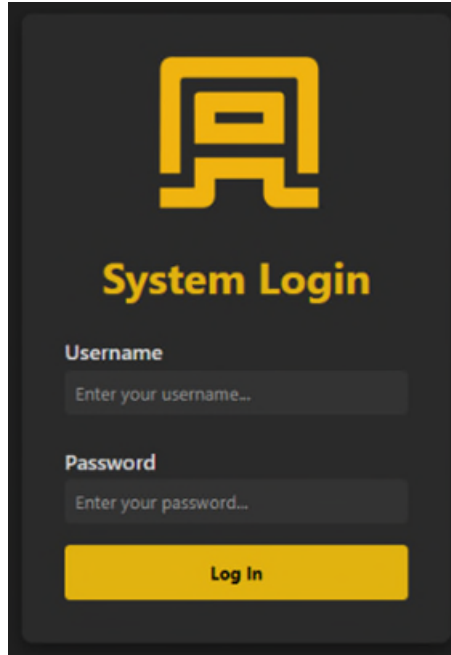
A dark-themed login screen with a yellow logo at the top. The logo is a stylized 'A' shape. Below the logo, the text 'System Login' is displayed in yellow. There are two input fields: 'Username' with the placeholder text 'Enter your username...' and 'Password' with the placeholder text 'Enter your password...'. A yellow 'Log In' button is at the bottom.

8.14.2.3 Login with the default credentials Username: admin Password: admin

8.14.2.4 You will now be prompted to change your username and password to something unique.

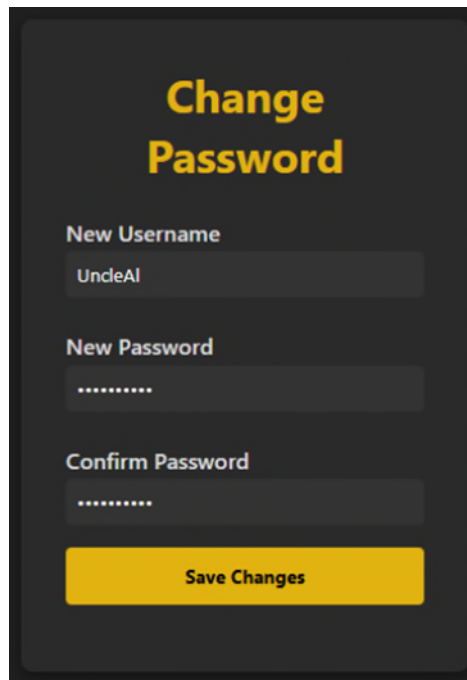
A dark-themed 'Change Password' screen. The title 'Change Password' is in yellow. There are three input fields: 'New Username' with the value 'UndeAl', 'New Password' with a masked password '.....', and 'Confirm Password' with a masked password '.....'. A yellow 'Save Changes' button is at the bottom.

8.14.2.5 Your password must be at least 8 characters, include an uppercase, lowercase, number, and special character.

8.14.2.6 You will now be prompted to login for the first time.

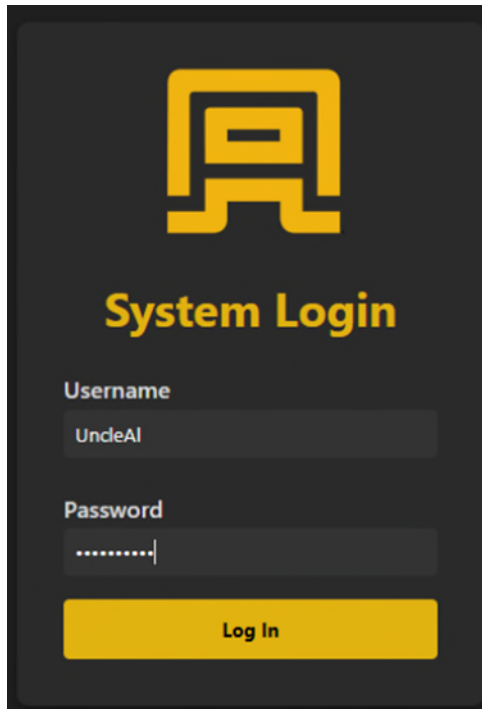

8.14.2.7 Once logged in, you will now notice that there are options to “Change Password” and Logout available in the top right-hand corner.

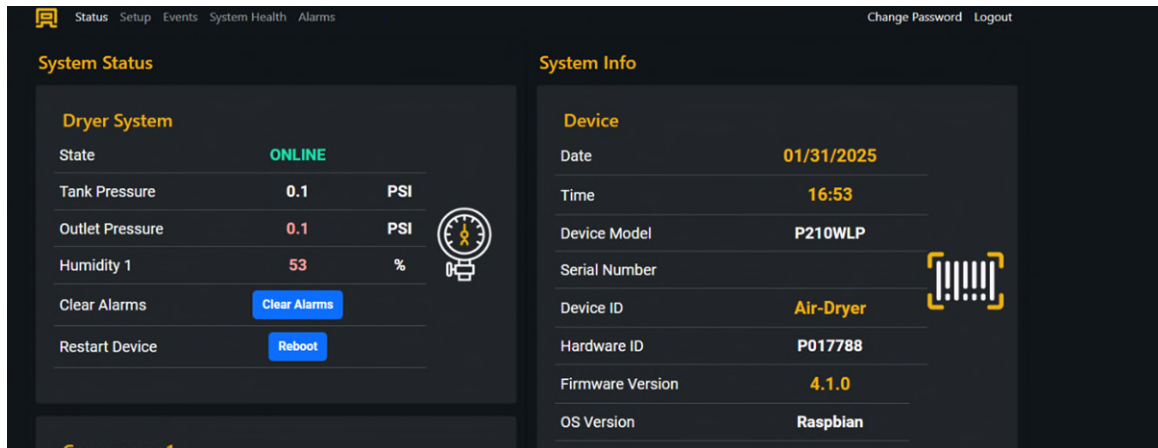

8.14.2.8 In the setup screen you will notice that there are options to.

8.14.2.8.1 Download a Certificate Signing Request, to get rid of the red lock indicating that the certificate is not valid.

8.14.2.8.2 SNMPV3 settings.

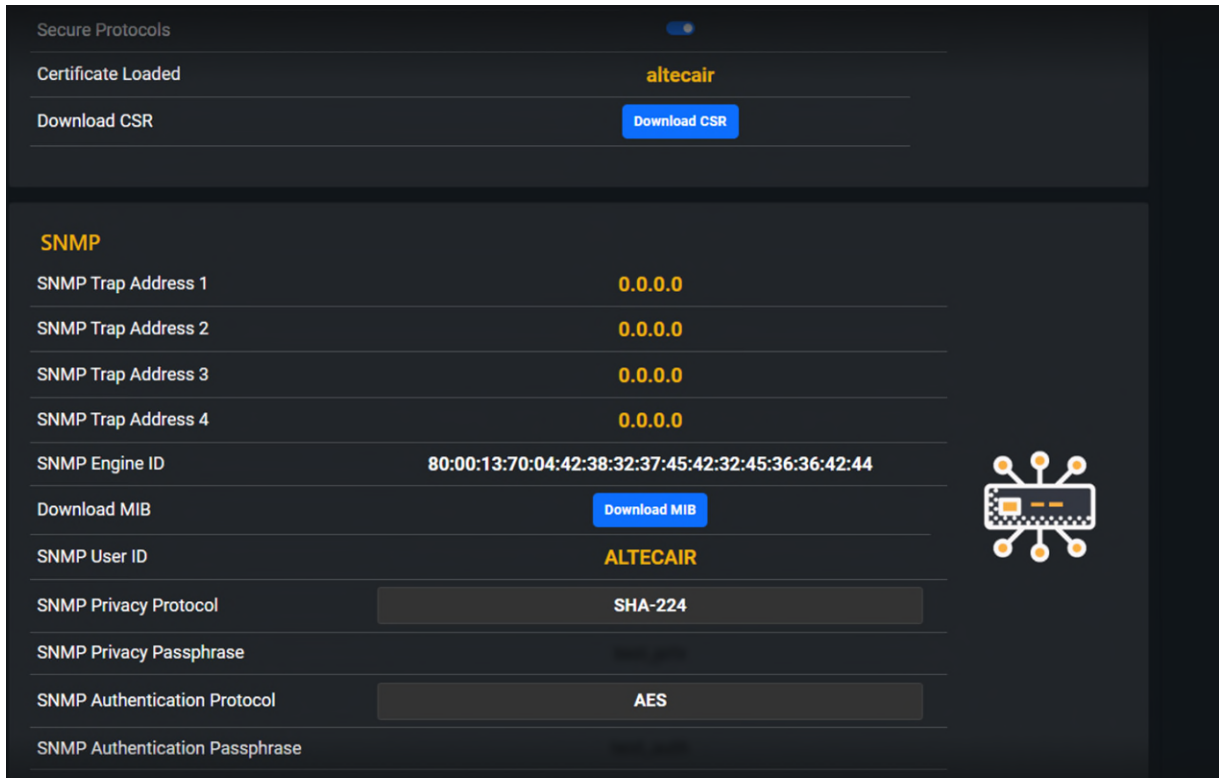

8.14.2.9 You may also notice that the events log has entries for user creation and login attempts

8.14.3 Disabling Secure Mode

To disable Secure Mode you can either login to the web browser and turn the secure mode switch off, or turn it off via the front panel lcd menu on the dryer itself. **Warning** disabling Secure Mode will delete all user accounts and certificates. You will need to reconfigure these if you re-enable Secure Mode.

8.15 Certificate Management

8.15.1 The device uses HTTPS with TLS certificates. Since we cannot guarantee the device is connected to the internet, we cannot use common web tools to provide signed certificates. This results in a “Not Secure” message in the web browser interface. The remedy to this situation is utilizing Certificate Signing Request as a protocol.

8.15.2 How To Download a CSR

8.15.2.1 Navigate to Setup > Network > Certificate

Click Download CSR

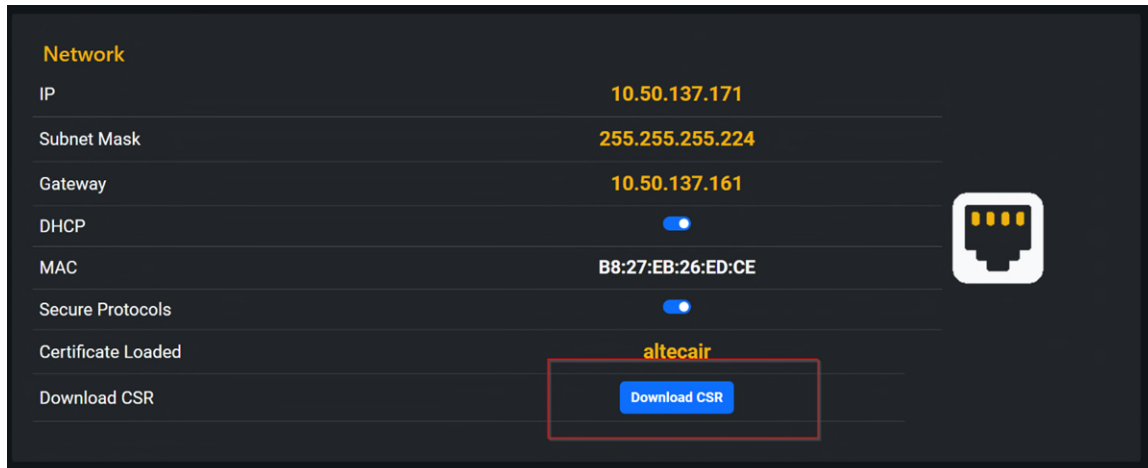

8.15.3 Sign The CSR

8.15.3.1 In the next step the user will have to sign the CSR using a desired root CA and private key. This section will require the user to have a basic understanding of using the command line on a unix system and have openssl installed on that system beforehand. If the user's organization does not have a root certificate and private key pairing already, then at this point one will have to be generated. This can be done using the openssl command below:

- Change \$DAYS to the number of days you want the certificate to be valid for.
- Change \$ROOTCAKEY to whatever you want to name your root private key
- Change \$ROOTCA to whatever you want the name of your root certificate to be.

```
openssl req -new -x509 -days $DAYS -keyout $ROOTCAKEY -out $ROOTCA
```

Next once the user has a root certificate, signing the CSR is as simple as using the openssl command below:

- Change \$DAYS to the time you want the signed certificate to be valid for.
- Change \$CSR_FILE to the path of the CSR that was downloaded from the dryer usually AltecDryer.csr.
- Change \$CA_CERT to the path of root CA cert
- Change \$KEYFILE to the path of the root CA key.
- Change \$OUT_CERT_NAME to whatever you want to name the certificate, keep in mind the dryer will use a .crt or .cert file extension when you do this.
- Change \$DEVICE_IP to the IP of the dryer, by default this is 192.168.1.102.

```
openssl x509 -req -in $CSR_FILE -days 365 -CA $CA_CERT -CAkey  
$KEYFILE -CAcreateserial -out $OUT_CERT_NAME -extfile  
<(printf "subjectAltName=IP:$DEVICE_IP")
```

8.15.4 Upload The Certificate

Finally upload the result certificate to the web browser. To begin, navigate back to the Network section under the Setup tab. Click on the name of the certificate that is currently uploaded. The menu below will pop up.

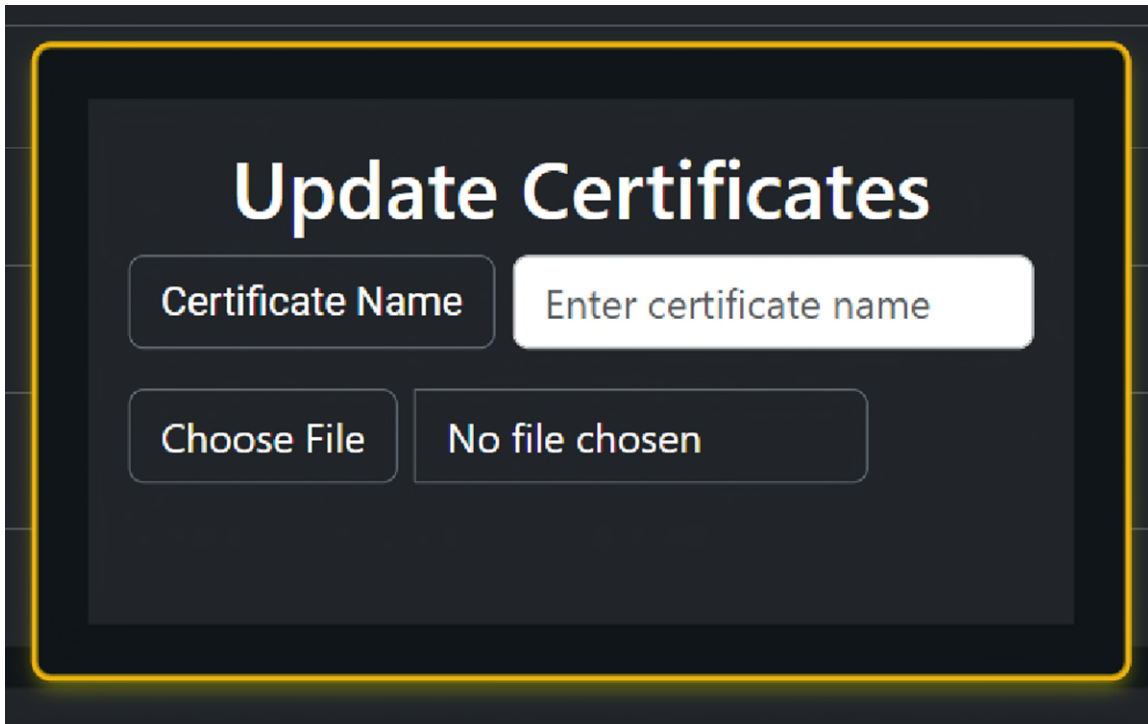

Update Certificates

Certificate Name

Choose File

In the upper box enter an alias to identify the certificate that is currently being uploaded. In the lower box chose the signed certificate as the file to upload. Finally with all the options filled out hit the Upload button. The new certificate will be uploaded, and the Altec Air dryer will be added to the users' network!

8.16 Connecting via SNMP

Using SNMP to connect and communicate with the P1500W Series Air Dryer is dependent upon the specific SNMP Management software used on your network. This software requires a SNMP Definition & Configuration File (MIB file) in order to properly communicate with the Air Dryer.

The files for the P1500W Series Air Dryers can be downloaded from our website (AltecAIR.com) under the Product Support section SNMP Files link. It is necessary to import this file into your SNMP operating software.

NOTE: Reference Appendix section 14.3 for a list of SNMP Parameters including Limits, Defaults, and Formats.

9. Testing Your Dryer

9.1 Safety & Warning Information



WARNING!

Extreme care should be exercised to avoid contact with live electrical circuits. Many procedures performed during installation, operation, testing, and maintenance of this air dryer require the equipment to be running, creating a situation for potential electrical shock. It is highly recommended that you remove all jewelry before performing any procedures.



WARNING!

Internal surfaces may be hot. Use care when coming into contact with internal components as there is a potential for some of these components to become hot when in operation or standby.



CAUTION!

Depressurizing the air dryer may be necessary before performing certain procedures. **NEVER** remove pressure sensing tubes from the control board without depressurizing the air dryer first, or **damage to the control board will occur.**

9.2 Measuring Compressor Amp Draw



WARNING!

Internal surfaces may be hot. Use care when coming into contact with internal components as there is a potential for some these components to become hot when in operation or standby.

With the Compressor running:

9.2.1 Open Front Panel (section 8.7).

9.2.2 Locate wire #5 coming directly from the Compressor.

9.2.3 Use an Amp Meter to measure the running amps. With the Compressor running, the running amps should measure:

- **6.3 amps or below** for the P1500W, P1500WLP & P1500WHP models
- **3.2 or below** for the P1502W, P1502WLP & P1502WHP models

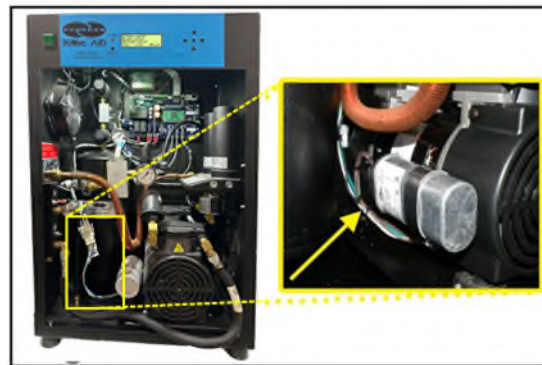

If the Compressor measures over running amps indicated above, see section 13.16 for troubleshooting information.

9.2.4 Close Front Panel.

9.3 Measuring Compressor Voltage



WARNING!

Extreme care should be exercised to avoid contact with live electrical circuits. It is highly recommended that you remove all jewelry before performing any procedures.

9.3.1 Open Front Panel (see section 8.7.

9.3.2 Locate the relay terminal block on the control board inside the air Dryer.

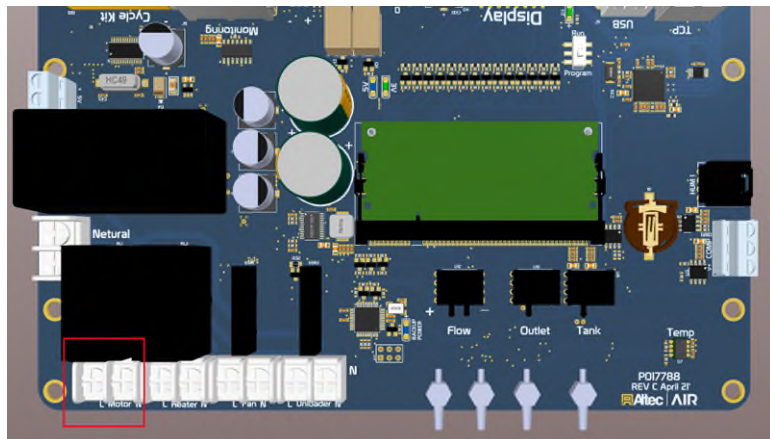

With the Compressor running:

9.3.3 Use a Voltmeter to measure across the board terminals where wires #5 and #6 are connected.

The voltage should measure **120 VAC (120V models) or 240 VAC (240V models)**

With the Compressor NOT running:

9.3.4 Use a Voltmeter to measure across the board terminals where wires #5 and #6 are connected.

The voltage should measure
0 VAC

If any of the voltage measurements are different than indicated above, the Control Board is defective and should be replaced. See sections 11.1 for part detail and 11.5 for ordering information.

9.3.5 Close Panel.

9.4 Measuring Incoming Voltage



WARNING!

Extreme care should be exercised to avoid contact with live electrical circuits. It is highly recommended that you remove all jewelry before performing any procedures.

9.4.1 Open Front Panel (section 8.7).

9.4.2 Locate the Incoming **POWER** connector inside the dryer.

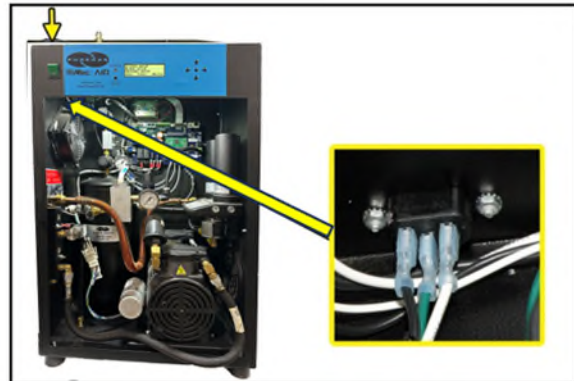

9.4.3 Use a Voltmeter to measure the voltage (inside dryer):

9.4.3.1 Place the probes between the Power Connector and terminal insulation so that they touch the metal contacts for **BLACK (BROWN)** wire and **WHITE (BLUE)** wire.

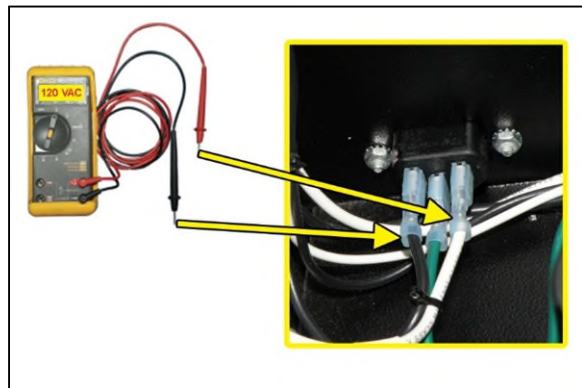

The voltage should measure:

- **110 - 125 VAC** for the P1500W, P1500WLP & P1500WHP models
- **208 - 230 VAC** for the P1502W, P1502WLP & P1502WHP models

If the incoming voltage measures less than indicated above, it is recommended that steps be taken at your facility to bring the power to the recommended level of voltage.

9.4.4 Close Front Panel.

9.5 Measuring Voltages at Solid State Relay

9.5.1 Open Front Panel (section 8.7).

9.5.2 Locate the Solid-State Relay inside the dryer at the top of back wall.

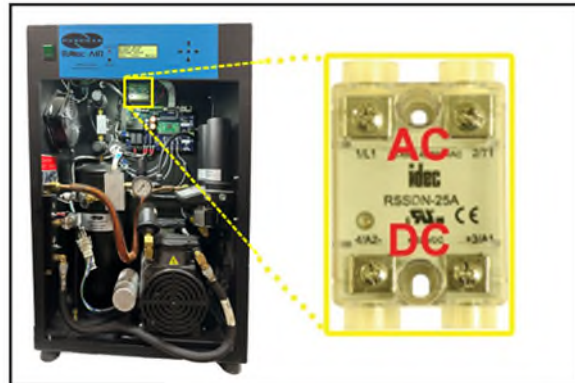

With Compressor running:

9.5.3 Use a Voltmeter to measure across the AC terminals.
Should measure **0 VAC**.

9.5.4 Use a Voltmeter to measure across the DC terminals.

Should measure: **5 VDC**

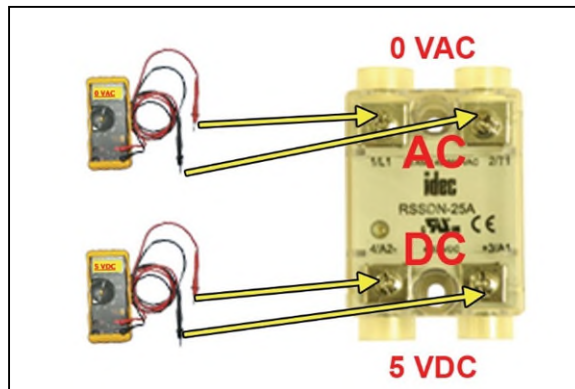

With Compressor NOT running:

9.5.5 Use a Voltmeter to measure across the AC terminals.

Should measure:

- **110 - 125 VAC** for the P1500W, P1500WLP & P1500WHP models
- **208 - 230 VAC** for the P1502W, P1502WLP & P1502WHP models

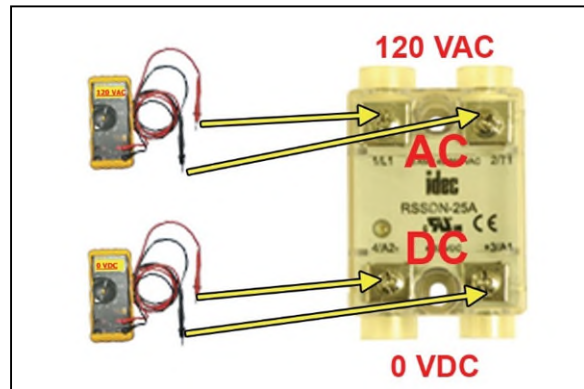

9.5.6 Use a Voltmeter to measure across the DC terminals.

Should measure **0 VDC**.

9.5.7 Close Front Panel.

If any of the AC voltage measurements are different than indicated above, the Solid-State Relay is defective and should be replaced.

If any of the DC voltage measurements are different than indicated above, the Control Board may be defective and should be replaced.

See sections 11.1 for part detail and 11.5 for ordering information.

9.6 Testing Consistent Heatless Dryer Cycling



WARNING!

Internal surfaces may be hot. Use care when coming into contact with internal components as there is a potential for some of these components to become hot when in operation or standby.

With Compressor running:

9.6.1 Open Front Panel (section 8.7).

9.6.2 Place a piece of insulating material over the Compressor for this test (*i.e. piece of cardboard*).

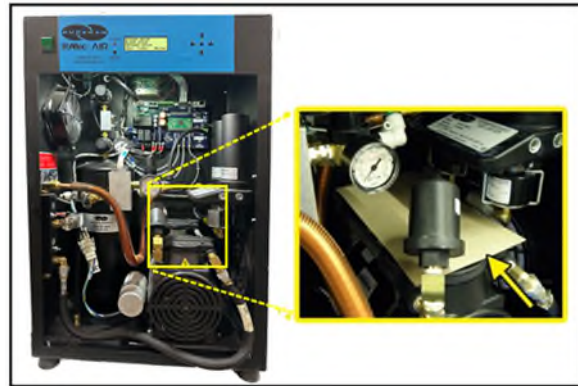

9.6.3 Locate the heatless dryer purge solenoids inside the air dryer.

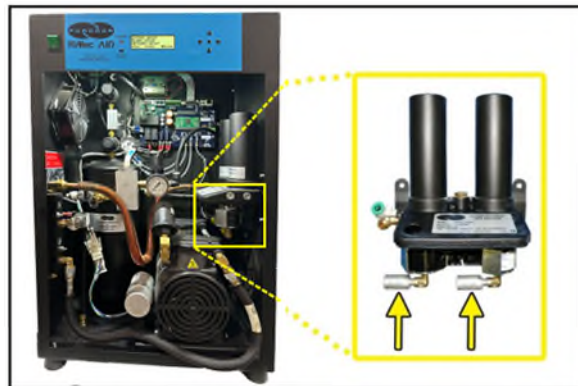

9.6.4 Place your hand beneath the purge solenoids to feel for purging air. Air should:

- Purge from Tower 1 side
- Purge from Tower 2 side
30 Seconds later
- Purge from Tower 1 side
30 Seconds later
- ...and so on.

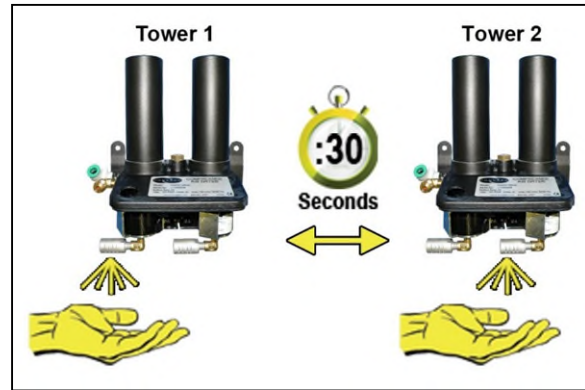

9.6.5 Remove insulating material from top of the Compressor.

9.6.6 Close Front Panel.

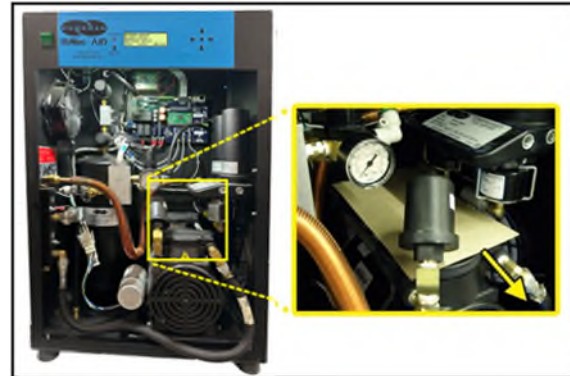

If the Heatless Dryer is not cycling consistently as described, see section 13.13 for troubleshooting information.

9.7 Testing Unloader Valve

With Compressor running:

9.7.1 Open Front Panel (section 8.7).

9.7.2 Locate the Unloader Valve on the left side of the Dryer.

9.7.3 With a 9/16" wrench disconnect hose from the Unloader Valve.

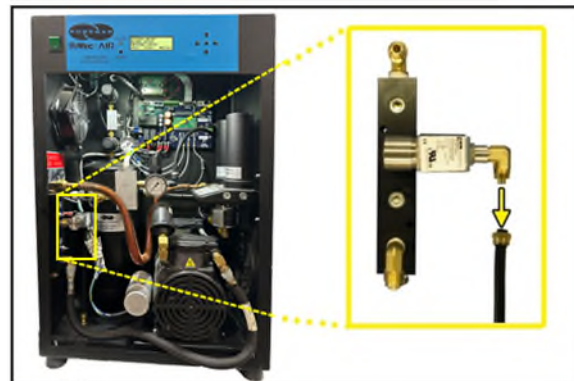

- 9.7.4** Place your hand under the Unloader Valve to verify for air flow.

The Unloader Valve should purge all the head pressure when the Compressor turns off, and for approximately 2 seconds when the Compressor starts up again.



If air flows from this valve continuously the Unloader Valve is defective and should be replaced. See sections 11.2 for part detail and 11.5 for ordering information.

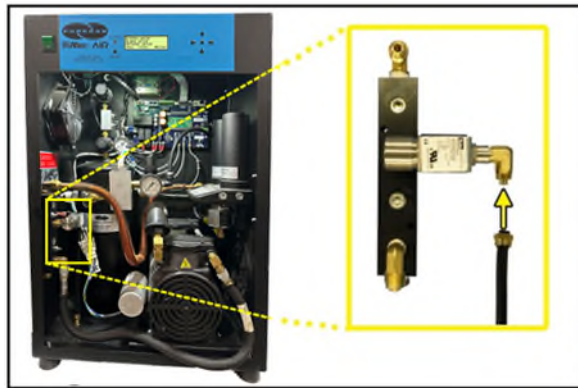

- 9.7.5** With a 9/16" wrench connect hose to the Unloader Valve.

- 9.7.6** Close Front Panel.

9.8 Measuring Heatless Dryer Solenoid Voltage

With Compressor running:

- 9.8.1** Open Front Panel (section 8.7).
- 9.8.2** Locate the Heatless Dryer Cycle Timer.

The timer has three (3) sets of terminals (from left-to-right):

“**VALVE**” – Left solenoid

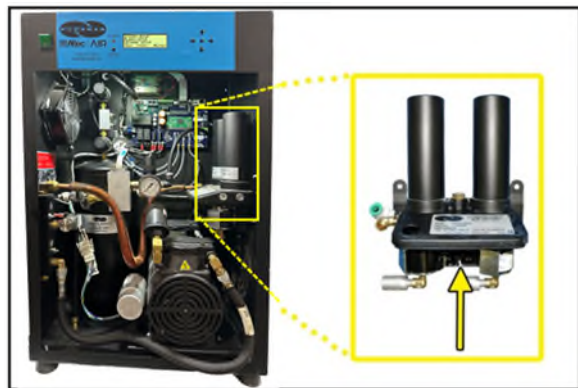

“IN” – Incoming power

“VALVE” – Right solenoid

9.8.3 Use a Voltmeter to measure the DC voltage across each set of “VALVE” terminals.

Continue to measure for up to 45 seconds if no voltage is initially measured.

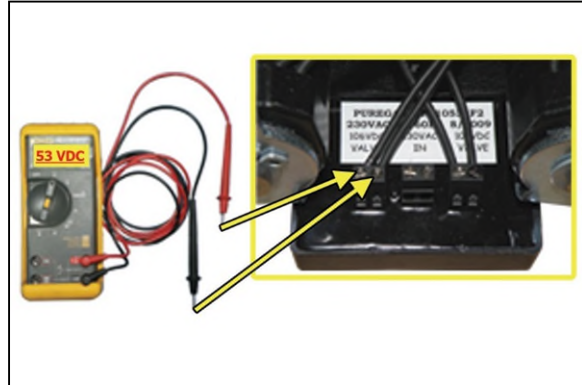

The voltage should measure:

- **53 VDC** for the P1500W, P1500WLP & P1500WHP models
- **106 VDC** for the P1502W, P1502WLP & P1502WHP models

9.8.4 Close Front Panel.

If the voltage does not measure as indicated above, this is an indication that the Cycle Timer is defective and should be replaced. See sections 11.3 for part detail and 11.5 for ordering information.

9.9 Testing Air Dryer Fan

NOTE: To test the fan, the cabinet temperature must be above 90°F (32.2°C).

9.9.1 Place your hand outside the dryer to feel for air being blown outwards.

NOTE: The fan will turn OFF when the cabinet temperature is below 80°F (26.7°C).



If the fan is not blowing air outwards as described:

- *Verify the cabinet temperature is above 90°F (32.2°C).*
- *Check for loose wiring. Refer to the Wiring Diagram (section 14.1)*
- *Replace defective fan (see sections 11.1 for part detail and 11.5 for ordering information).*
- *Replace defective Control Board if fan does not respond properly to temperature changes (see sections 11.2 for part detail and 11.5 for ordering information).*

9.10 Testing Safety Relief Valve

9.10.1 Open Front Panel (section 8.7).

9.10.2 Pull the ring handle on the Safety Relief Valve to verify air pressure is released.

9.10.3 Release ring handle and verify that no air is leaking from the valve.

9.10.4 Close Front Panel.

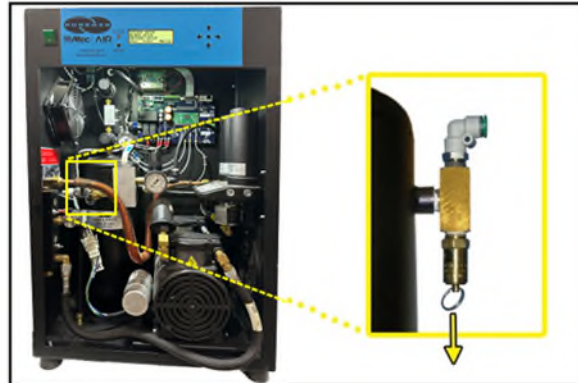

If the Safety Relief Valve fails either test described, it must be replaced. See sections 11.2 for part detail and 11.5 for ordering information.

9.11 Testing Compressor ON/OFF Cycling

9.11.1 Open Front Panel (section 8.7).

9.11.2 When the Unit Screen (8.2.5.1) appears on the display, press the **HOLD Button** on the Front Panel to freeze that screen.

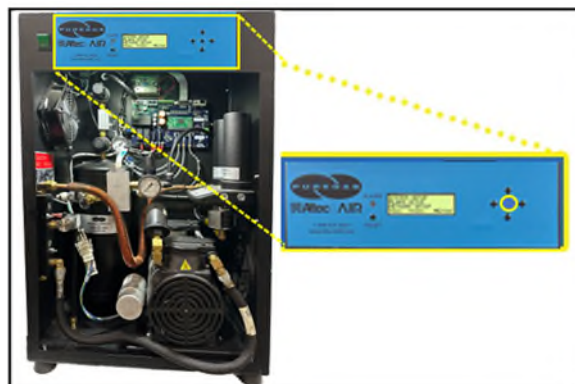

With Compressor running:

- 9.11.3** Verify the Compressor shuts down when the tank pressure (**TANK**) reaches **90.0 PSI (620.5 KPa)**.

*If the tank pressure (**TANK**) fails to reach 90 PSI (620.5 KPa), see section 13.15 for troubleshooting information.*

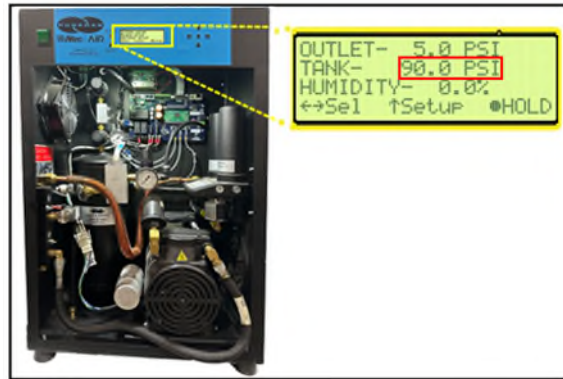
**With Compressor NOT running:**

- 9.11.4** Pull the ring handle on the Safety Relief Valve to release air pressure from the air tank.

- 9.11.5** Verify the Compressor turns on when the tank pressure (**TANK**) falls to:

- **25.0 PSI* (172.4 KPa)** for the P1500W/2, P1500WLP, P1502W, & P1502WLP models. *(50 PSI (344.7 KPa) for Dryers using Firmware v2.84 and older)
- **60.0 PSI** for the P1500WHP & P1502WHP models

- 9.11.6** Close Front Panel

If the Compressor Cycling fails either test described, it indicates a problem with the Control Board which will need to be replaced. See sections 11.2 for part detail and 11.5 for ordering information.

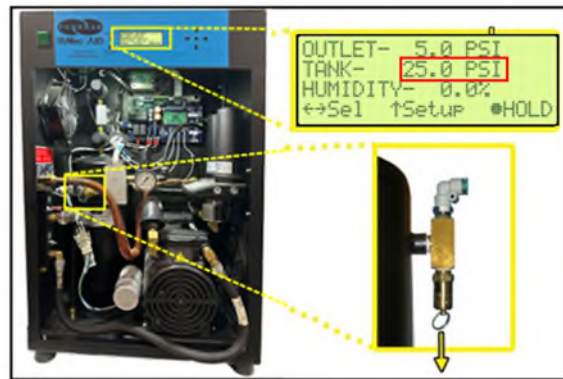
**9.12 Testing High Compressor Last Run Time Alarm**

NOTE: For this test, allow the Display Screen to cycle through the information screens.

- 9.12.1** Open Front Panel (section 8.7).

- 9.12.2** Start timing when the Compressor turns on.

- 9.12.3** Pull the ring handle on the Safety Relief Valve (when necessary) to keep the Tank Pressure (**TANK**) from reaching **90 PSI (620.5 KPa)**. *This prevents the Compressor from shutting down.*

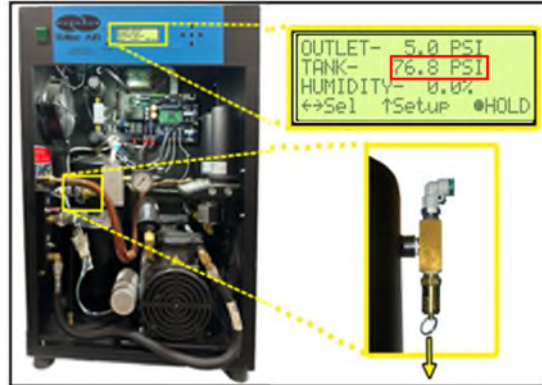

- When the Compressor runs for 3:00 minutes (unless adjusted to a different Set Point by the user), a High Compressor Last Run Time (**LAST RUN**) alarm should appear on the System Screen.



- 9.12.4** Press the **RESET Button**.

- 9.12.5** Close Front Panel.



*If you are unable to create a High Compressor Last Run Time (**LAST RUN**) alarm as described, see section 13.18 for troubleshooting information.*

9.13 Testing Humidity Alarm and System Shutdown

- 9.13.1** Power the air dryer **OFF**.

- 9.13.2** Open Front Panel (section 8.7).

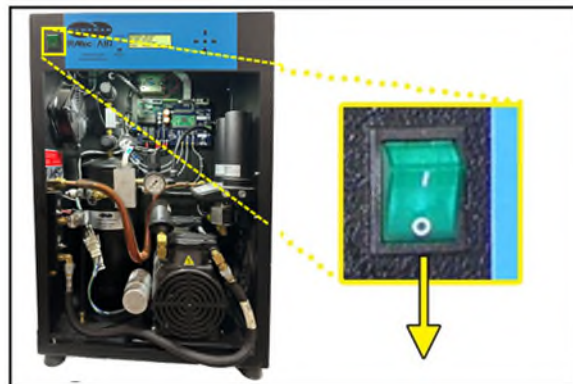

9.13.3 Depressurize the air dryer.

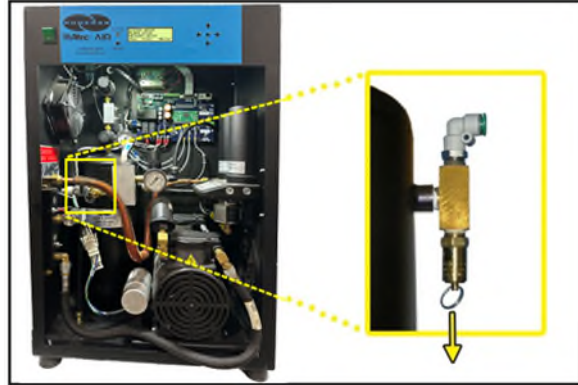

9.13.4 Unscrew and remove the Humidity Sensor from the Humidity Block.

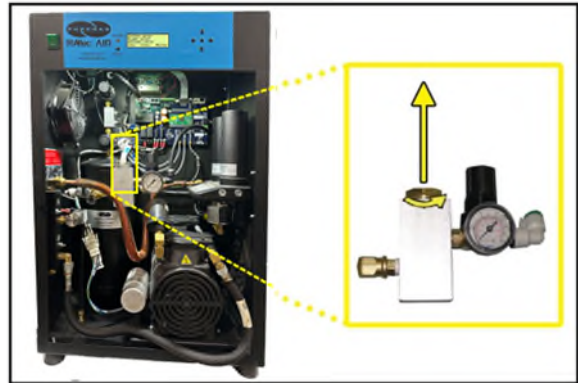

9.13.5 Power the air dryer ON.

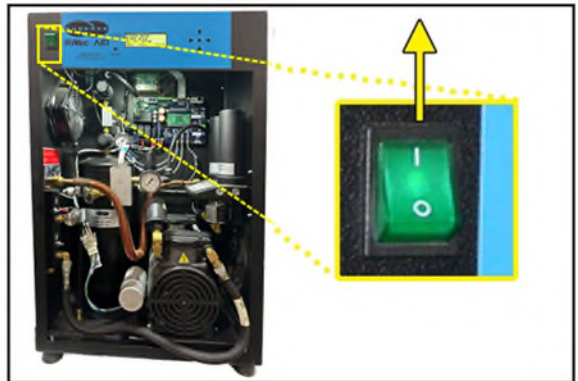

9.13.6 Allow the Humidity reading to rise over 10.0%

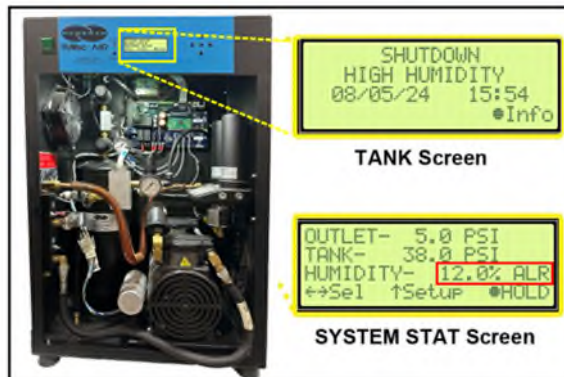

After three (3) minutes, verify that a Humidity Alarm appears, and the dryer goes into **SHUTDOWN** mode.

- 9.13.7** Replace the Humidity Sensor into the Humidity Block.

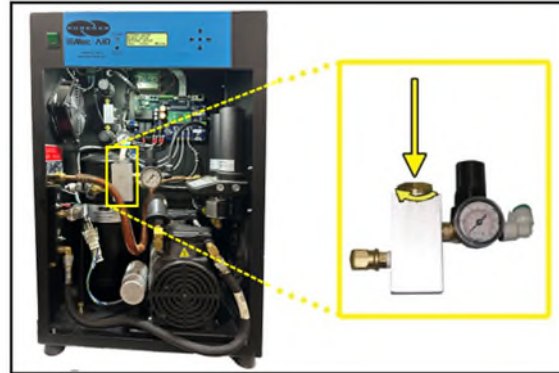

- 9.13.8** Press the **RESET Button** to clear the Humidity alarm.

- 9.13.9** Close Front Panel.

If you are unable to create a Humidity / Shutdown alarm as described, see section 13.10 for troubleshooting information.

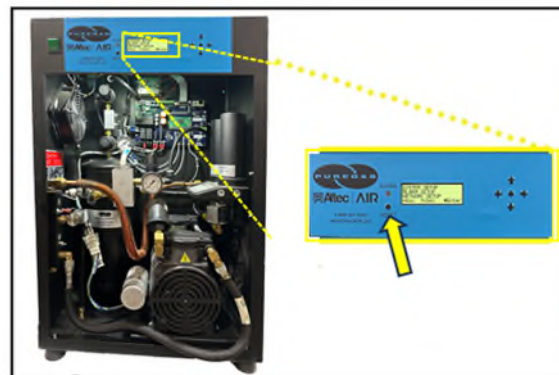

9.14 Testing High Outlet Pressure Alarm

- 9.14.1** Make a note of the current Outlet Pressure (**OUTLET**) reading.

- 9.14.2** Open Front Panel (section 8.7).

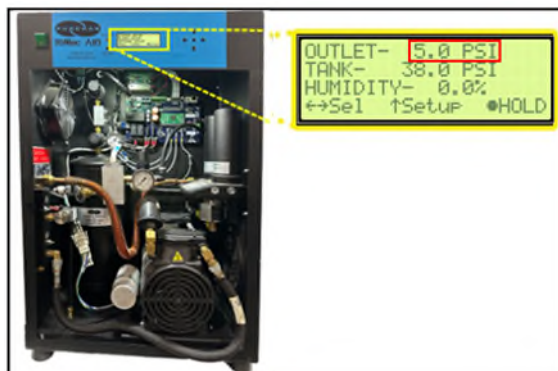

Pull the Outlet Pressure Regulator knob out (or loosen the retaining nut – LP Models).

- 9.14.3**

9.14.4 Turn knob clockwise until Outlet Pressure (**OUTLET**) reading climbs

over:

- **12.0 PSI (82.7 KPa)** for P1500W & P1502W models
- **7.50 PSI (51.5 KPa)** for P1500WLP & P1502WLP models
- **35.0 PSI (241.3 KPa)** for P1500WHP & P1502WHP models

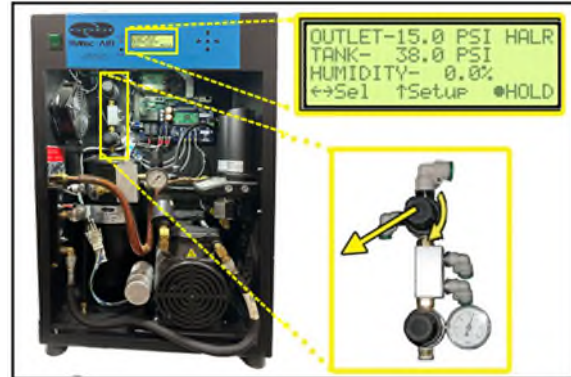

After one (1) minute, the High-Pressure Alarm should appear on the display.

9.14.5 Turn Outlet Pressure Regulator knob counterclockwise until Outlet Pressure (**OUTLET**) reading lowers to the reading recorded in step 9.14.1



9.14.6 Push knob in to lock (or tighten the retaining nut – LP Models).

9.14.7 Press the **RESET Button**.

9.14.8 Close Front Panel.

If you are unable to create a High Outlet Pressure Alarm as described, see section 13.6 for troubleshooting information.

9.15 Testing Low Outlet Pressure Alarm

9.15.1 Make a note of the current Outlet Pressure (**OUTLET**) reading.



9.15.2 Open Front Panel (section 8.7).

9.15.3 Pull the Outlet Pressure Regulator knob out (or loosen the retaining nut – LP Models).

9.15.4 Turn knob counterclockwise until Outlet Pressure (**OUTLET**) reading drops **below:**

6.5 PSI (41.4 KPa) for P1500W & P1502W models

0.30 PSI (2.1 KPa) for P1500WLP & P1502WLP models (example shown)

25.0 PSI (172.4 KPa) for P1500WHP & P1502WHP models

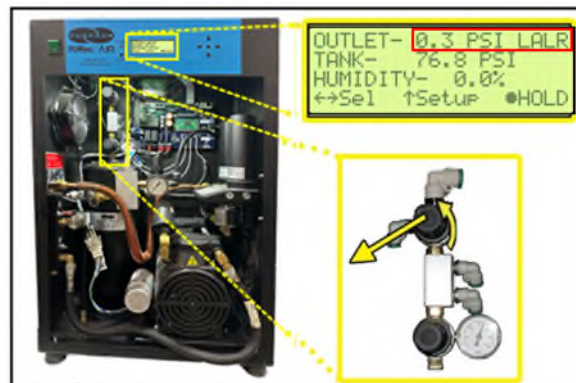

After one (1) minute, the Low-Pressure Alarm should appear on the display.

9.15.5 Turn Outlet Pressure Regulator knob clockwise until Outlet Pressure (**OUTLET**) reading rises to the reading recorded in step 9.15.1



9.15.6 Push knob in to lock (or tighten the retaining nut – LP Models).

9.15.7 Press the **RESET Button**.

9.15.8 Close Front Panel.

If you are unable to create a Low Outlet Pressure Alarm as described, see section 13.8 for troubleshooting information.

9.16 Testing Air Fittings & Hoses for Leaks

NOTE: This is a general procedure that can be applied to any fitting or hose that has air pressure in it. **DO NOT SOAP TEST THE HUMIDITY SENSOR FITTING. DAMAGE TO THE SENSOR MAY OCCUR.**

With Compressor NOT running:

9.16.1 Listen for any 'hissing' sounds which may indicate a fitting or hose air leak.

With Compressor running:

9.16.2 Use a 1-inch paint brush to dab soapy water on the air fitting or hose connection to be tested.

If air bubbles appear at the connection, this indicates that air is leaking from the connection.

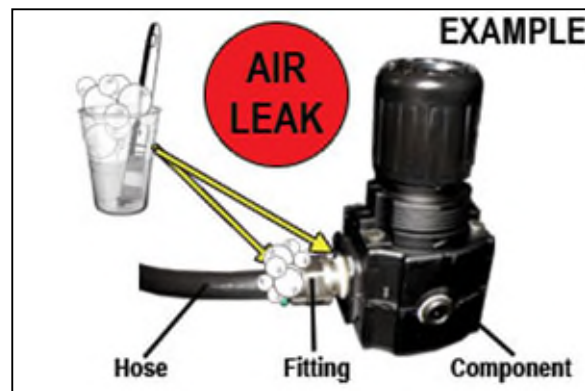

If any leaks are detected, take steps to seal them off (as necessary):

- *Tighten the fitting*
- *Re-connect the hose end*
- *Replace the fitting / hose / component*

10. Maintaining Your Dryer

In order to ensure that your P1500W Series Air Dryer continues to operate efficiently and reliably, ALTEC AIR recommends performing the following maintenance procedures at the specified Six Month and 8,000 Hour intervals.

It is also recommended that you print out the included *Six Month Maintenance (section 10.2)* and *8,000 Hour Maintenance (section 10.3)* log sheets and record all completed maintenance for historical tracking and reference purposes.

The log sheets include a Section reference column which indicates the User's Guide section containing the information about the specific procedure. Please refer to these sections for detailed procedural information.

NOTE: When operating at higher ambient temperatures, it is recommended that maintenance be performed more frequently.

NOTE: After 16,000 hours of run time, ALTEC AIR recommends sending in your Compressors and heatless dryers for a complete and comprehensive rebuild by our Service Department technicians. *See sections 12.1 and 12.2 for information on services and contacting ALTEC AIR.*

10.1 Safety & Warning Information



WARNING!

Extreme care should be exercised to avoid contact with live electrical circuits. Many procedures performed during installation, operation, testing, and maintenance of this air dryer require the equipment to be running, creating a situation for potential electrical shock. It is highly recommended that you remove all jewelry before performing any procedures.



WARNING!

Internal surfaces may be hot. Use care when coming into contact with internal components as there is a potential for some of these components to become hot when in operation or standby.



CAUTION!

SHUT DOWN IMMEDIATELY FOR REPAIRS if the air Compressor shows any evidence of overheating or presents excessive noise.



CAUTION!

Depressurizing the air dryer may be necessary before performing certain procedures. **NEVER** remove pressure sensing tubes from the Control Board without depressurizing the air dryer first, or **damage to the Control Board will occur.**



IMPORTANT!

Performing routine maintenance as outlined in the *Maintaining Your Dryer* section will ensure optimal performance over the lifecycle of your air dryer.

**IMPORTANT!**

Performing procedures not described in this User's Guide or installing components not supplied by ALTEC AIR is NOT RECOMMENDED AND MAY VOID THE WARRANTY.

**IMPORTANT!**

After performing any maintenance, always soap test pressure fittings to check for air leaks. Also, check for any loose or disconnected wiring.

10.2 Six Month Maintenance

MODEL: _____

LOCATION NAME: _____

SERIAL NUMBER: _____

ADDRESS: _____

DATE INSTALLED: _____

Procedure	Section	Maintenance Interval (Months)				
		6	12	18	24	30
Install Six Month Maintenance Kit	11.4	<input type="checkbox"/>	<input type="checkbox"/>	<input type="checkbox"/>	<input type="checkbox"/>	<input type="checkbox"/>
Read & Record Flow Rate (FLOW)	8.3.1					
Measure & Record Compressor Amp Draw	9.2					
Measure & Record Incoming Voltage: <ul style="list-style-type: none"> • 110 - 125 VAC for P1500W, P1500WLP & P1500WHP models • 208 - 230 VAC for P1502W, P1502WLP & P1502WHP models 	9.4					
Set System Pressure: <ul style="list-style-type: none"> • 80 PSI (551.6 KPa) for P1500W, P1500WLP, P1502W & P1502WLP models • 90 PSI (620.5 KPa) for P1500WHP & P1502WHP models 	6.5.13	<input type="checkbox"/>	<input type="checkbox"/>	<input type="checkbox"/>	<input type="checkbox"/>	<input type="checkbox"/>
Set Static Pressure: <ul style="list-style-type: none"> • 17 PSI (117.2 KPa) for P1500W, P1500WLP, P1502 & P1502WLP models • 60 PSI (413.7 KPa) for P1500WHP & P1502WHP models 	6.5.24	<input type="checkbox"/>	<input type="checkbox"/>	<input type="checkbox"/>	<input type="checkbox"/>	<input type="checkbox"/>
Set Outlet Pressure	6.5.25	<input type="checkbox"/>	<input type="checkbox"/>	<input type="checkbox"/>	<input type="checkbox"/>	<input type="checkbox"/>
Test Consistent Heatless Dryer Cycling	9.6	<input type="checkbox"/>	<input type="checkbox"/>	<input type="checkbox"/>	<input type="checkbox"/>	<input type="checkbox"/>
Test Fan	9.9	<input type="checkbox"/>	<input type="checkbox"/>	<input type="checkbox"/>	<input type="checkbox"/>	<input type="checkbox"/>
Test Compressor ON/OFF Cycling	9.11	<input type="checkbox"/>	<input type="checkbox"/>	<input type="checkbox"/>	<input type="checkbox"/>	<input type="checkbox"/>
Test High Compressor Last Run Time Alarm	9.12	<input type="checkbox"/>	<input type="checkbox"/>	<input type="checkbox"/>	<input type="checkbox"/>	<input type="checkbox"/>
Test Humidity Alarm & System Shutdown	9.13	<input type="checkbox"/>	<input type="checkbox"/>	<input type="checkbox"/>	<input type="checkbox"/>	<input type="checkbox"/>
Test High & Low Outlet Pressure Alarms	9.14 & 9.15	<input type="checkbox"/>	<input type="checkbox"/>	<input type="checkbox"/>	<input type="checkbox"/>	<input type="checkbox"/>
Test Air Fittings for Leaks	9.16	<input type="checkbox"/>	<input type="checkbox"/>	<input type="checkbox"/>	<input type="checkbox"/>	<input type="checkbox"/>
Visually Inspect Inside & Outside of Unit for Loose Wiring or Hardware		<input type="checkbox"/>	<input type="checkbox"/>	<input type="checkbox"/>	<input type="checkbox"/>	<input type="checkbox"/>
Maintenance Performed by:						
Date of Maintenance:						

NOTE: COPY OR PRINT THIS PAGE AND KEEP IT WITH THE AIR DRYER

10.3 8,000 Hour Maintenance

Under typical operating conditions:

8,000 hours of run time will occur between one (1) and two (2) years of use.

This will be identified by a **TTL TIME** Alarm on the display.

MODEL: _____

LOCATION NAME: _____

SERIAL NUMBER: _____

ADDRESS: _____

DATE INSTALLED: _____

Procedure	Section	Maintenance Interval (Hours)				
		8,000	16,000	24,000	32,000	40,000
Install 8,000 Hour Maintenance Kit	11.4	<input type="checkbox"/>	<input type="checkbox"/>	<input type="checkbox"/>	<input type="checkbox"/>	<input type="checkbox"/>
Read & Record Flow Rate (FLOW)	8.2					
Measure & Record Compressor Amp Draw	9.2					
Set System Pressure: <ul style="list-style-type: none"> • 80 PSI (551.6 KPa) for P1500W, P1500WLP, P1502W & P1502WLP models • 90 PSI (620.5 KPa) for P1500WHP & P1502WHP models 	6.5.13	<input type="checkbox"/>	<input type="checkbox"/>	<input type="checkbox"/>	<input type="checkbox"/>	<input type="checkbox"/>
Set Static Pressure: <ul style="list-style-type: none"> • 17 PSI (117.2 KPa) for P1500W, P1500WLP, P1502W & P1502WLP models • 60 PSI (413.7 KPa) for P1500WHP & P1502WHP models 	6.5.24	<input type="checkbox"/>	<input type="checkbox"/>	<input type="checkbox"/>	<input type="checkbox"/>	<input type="checkbox"/>
Set Outlet Pressure	6.5.25	<input type="checkbox"/>	<input type="checkbox"/>	<input type="checkbox"/>	<input type="checkbox"/>	<input type="checkbox"/>
Test Consistent Heatless Dryer Cycling	9.6	<input type="checkbox"/>	<input type="checkbox"/>	<input type="checkbox"/>	<input type="checkbox"/>	<input type="checkbox"/>
Test Compressor ON/OFF Cycling	9.11	<input type="checkbox"/>	<input type="checkbox"/>	<input type="checkbox"/>	<input type="checkbox"/>	<input type="checkbox"/>
Test Air Fittings for Leaks	9.16	<input type="checkbox"/>	<input type="checkbox"/>	<input type="checkbox"/>	<input type="checkbox"/>	<input type="checkbox"/>
Reset TTL TIME Reading to Zero	8.5.7	<input type="checkbox"/>	<input type="checkbox"/>	<input type="checkbox"/>	<input type="checkbox"/>	<input type="checkbox"/>
Visually Inspect Inside & Outside of Unit for Loose Wiring or Hardware		<input type="checkbox"/>	<input type="checkbox"/>	<input type="checkbox"/>	<input type="checkbox"/>	<input type="checkbox"/>
Maintenance Performed by:						
Date of Maintenance:						

NOTE: COPY OR PRINT THIS PAGE AND KEEP IT WITH THE AIR DRYER

11. Replacement Parts & Accessories

11.1 Dryer Parts

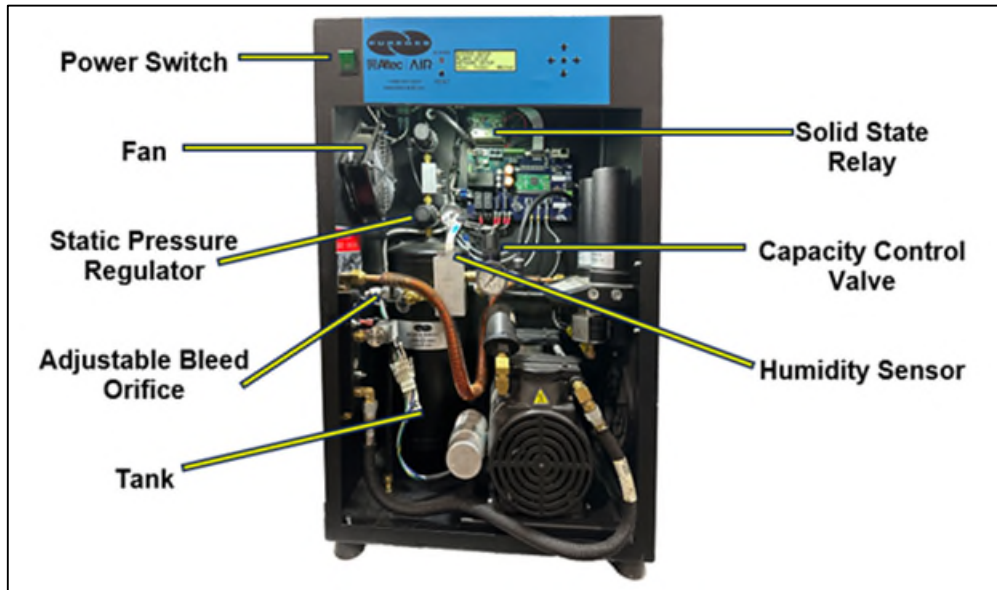

Description	Part Number	Quantity	Recommend Spare
Adjustable Bleed Orifice Valve Shut Off	100522051 100508601	1	
Power Switch	M038428	1	
Fan P1500W Series (110 VAC) P1502W Series (220 VAC)	P4080 P40801	1	
Static Pressure Regulator - W & WLP WHP	P010279 P010622	1	
Air Tank	P011609	1	
Solid State Relay	P05992	1	✓ (1)
Static Pressure Gauge - W & WLP WHP	P8345 P3197	1	
Capacity Control Valve	P010492	1	✓ (1)
Humidity Sensor	P013401	1	

11.2 Dryer Parts cont.

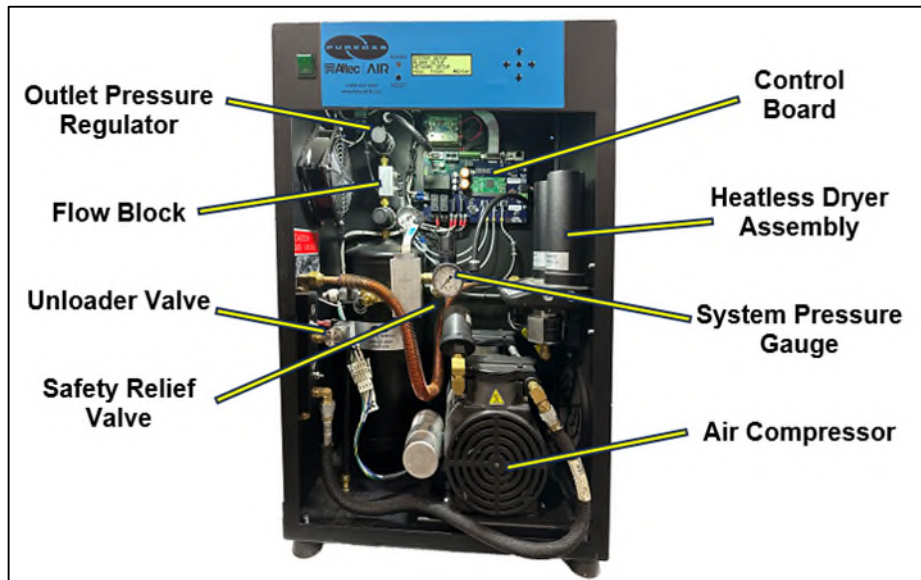





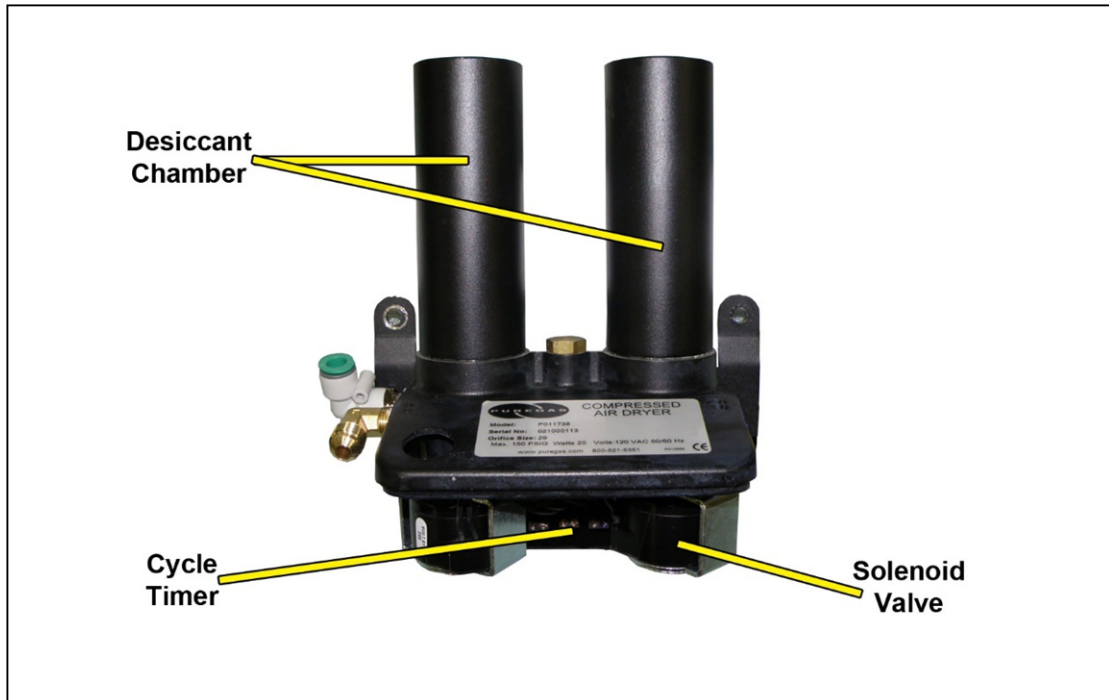

Description	Part Number	Quantity	Recommend Spare
Outlet Pressure Regulator – W WLP WHP	P010279 P012316 P010622	1	
Flow Block	P011795	1	
Unloader Valve - P1500W Series (110 VAC) P1502W Series (220 VAC)	P011022 P010453	1	
Safety Relief Valve	P011777	1	
Control Board	P013708	1	✓ (1)
Heatless Dryer Assembly	<i>See section Error! Reference source not found.3 for detail.</i>		
System Pressure Gauge	P010695	1	
Air Compressor – P1500W Series (110 VAC) P1502W Series (220 VAC)	P011781 P011873	1	✓ (1)

11.3 Heatless Dryer Assembly



Description	Part Number	Quantity	Recommend Spare
Heatless Dryer - P1500W Series (110 VAC) P1502W Series (220 VAC)	PHF2C106023 PHF2C20623	1	
Desiccant Chamber	P2004036	2	
Cycle Timer - P1500W Series (110 VAC) P1502W Series (220 VAC)	P010530F1 P010530F2	1	
Solenoid Valve Kit	<i>In Kit P012252. See section 11.4 for detail.</i>		

11.4 Accessories for Your Dryer

	Description	Part Number	Recommend Spare
	Six Month Maintenance Kit Includes air intake filter, Compressor muffler	P018302	✓ (2)
	8,000 Hour Maintenance Kit Includes heatless dryer maintenance kit and Compressor maintenance kit.	P012252	✓ (1)
	Universal Rack Mounting Kit Includes mounting brackets and hardware for 19" or 23" racks.	P011674	
	Wall Mounting Kit Includes mounting brackets and hardware.	P011773	
	Cycle Kit Allows multiple dryers to be cycled.	P08033W	
	Cycle Kit Interface Kit	PVDW34	

11.5 Ordering Parts from ALTEC AIR

Instruction for the replacement of individual listed components goes beyond the scope of this User's Guide and will not be covered. Please refer to the information included with the specific replacement part for this instruction.

Once you have identified your required parts and accessories, contact the ALTEC AIR Inside Sales / Service department to order:

(800) 521-5351 (option 2)

Fax – (303) 657-2205

sales@AltecAIR.com

12. Service & Repair

Only ALTEC AIR can offer factory direct rebuilds backed by a six-month factory warranty.

- 2-week turnaround time
- Estimates available upon request
- Minimum service charge fee applies

12.1 Services Offered

- **Piston Compressor Rebuild**
 - Replace motor bearings, piston rod assemblies, and install a complete Compressor maintenance kit.
 - Test air flow, air pressure, and electrical performance
- **Heatless Dryer Rebuild**
 - Replace desiccant, o-rings, check valves, springs, and complete solenoid assembly
 - Test proper component operation
- **Desiccant Tower Repack**
 - Clean out tower and replace desiccant, filter, and o-ring
- **Circuit Board Repair** (Limited to current model boards only)
- **Complete Dryer Repair**

12.2 Initiating a Service Transaction

- Contact our Parts & Service Department at **1-800-521-5351 (option 3)** to obtain a Return Authorization (RA) number.
- Carefully package the item(s) to be returned.
- Mark the Return Authorization (RA) number on the outside of the shipping container.
- Include the main address and phone number of the individual to contact for related inquiry and follow-up information.
- Include the purchase order number.

13. Troubleshooting Your Dryer

13.1 Before You Call ALTEC AIR

PLEASE READ THIS SECTION FIRST. It is important that you use the following sections in order to diagnose and attempt to fix the problem with your air dryer before placing a call to ALTEC AIR Technical Support.

This troubleshooting guide is intended to simplify the isolation of problems, present possible causes, provide test procedures for verification, and suggest corrective actions to restore the air dryer back to normal operation. Each section begins with the most likely cause(s) of the issue. Otherwise, they start from the simplest possibilities and progress to more complicated ones.

This troubleshooting guide is designed to be easy to follow and very effective when used properly. It is suggested to always start at the beginning of the specific problem section and continue in sequence, following the procedures indicated.

13.2 Safety & Warning Information



WARNING!

For your safety, all the information in this User's Guide must be followed to minimize the risk of electrical shock and prevent property damage or personal injury.



WARNING!

Internal surfaces may be hot. Use care when coming into contact with internal components as there is a potential for some of these components to become hot when in operation or standby.



WARNING!

Extreme care should be exercised to avoid contact with live electrical circuits. Many procedures performed during installation, operation, testing, and maintenance of this air dryer require the equipment to be running, creating a situation for potential electrical shock. It is highly recommended that you remove all jewelry before performing any procedures.



CAUTION!

Depressurizing the air dryer may be necessary before performing certain procedures. **NEVER** remove pressure sensing tubes from the Control Board without depressurizing the air dryer first, or **damage to the Control Board will occur.**



IMPORTANT!

Performing procedures not described in this User's Guide or installing components not supplied by ALTEC AIR is **NOT RECOMMENDED AND MAY VOID THE WARRANTY.**



CAUTION!

Do not test the Humidity Sensor with an ohm meter or apply any DC voltage. This will render the Humidity Sensor defective.

13.3 Air Dryer Won't Power ON

Possible Cause	Check	Corrective Action
POWER Switch in OFF position	Verify POWER switch is in the ON position	Turn POWER switch to the ON position
No incoming voltage to air dryer	Measure incoming voltage (section 9.4)	Troubleshoot facility power supply to air dryer

13.4 Display Screen Not Functioning

Possible Cause	Check	Corrective Action
Dryer experienced a power spike	Incoming power coming to the dryer	Power the air dryer OFF for 15+ seconds. Power the air dryer ON .
Ribbon cable disconnected	Verify ribbon cable from the decal is connected at the display board	Reconnect the ribbon cable properly.

13.5 High Outlet Pressure Alarm

Possible Cause	Check	Corrective Action
Outlet Pressure set too high	Verify Outlet Pressure (OUTP) reading (section 8.2.5.1)	Adjust Outlet Pressure Regulator
High Outlet Pressure Alarm set point too low	Verify High Outlet Pressure Alarm set point	Raise High Outlet Pressure Alarm set point

13.6 Can't Create a High-Pressure Alarm

Possible Cause	Check	Corrective Action
Defective Outlet Pressure Regulator	Verify that the Outlet Pressure Regulator can be adjusted	Replace Outlet Pressure Regulator if unable to adjust pressure (section 11.2)
High Outlet Pressure Alarm set point higher than default setting	Verify High Outlet Pressure Alarm set point	Adjust Outlet Pressure Regulator so that Outlet Pressure (OUTLET) reading climbs over verified set point (section 9.14)
Defective Control Board	Verify that the Outlet Pressure (OUTLET) reading is higher than the High Outlet Pressure Alarm set point (above)	Replace Control Board (section 11.2) if Outlet Pressure (OUTLET) reading is over verified High Outlet Pressure Alarm set point for more than 1 minute and fails to create an alarm.

13.7 Low Outlet Pressure Alarm

Possible Cause	Check	Corrective Action
Outlet Pressure set too low	Verify Outlet Pressure (OUTLET) reading (section 8.2.5.1)	Adjust Outlet Pressure Regulator
High Flow condition	Verify Flow Rate (FLOW) reading is not higher than expected	Troubleshoot High Flow condition (section 13.11)
Low Outlet Pressure Alarm set point too high	Verify Low Outlet Pressure Alarm set point	Lower the Low Outlet Pressure Alarm set point
Leak in the air system	With no outlet flow, test fittings and hoses for leaks (section 9.16)	Tighten any loose connections as required

13.8 Can't Create a Low-Pressure Alarm

Possible Cause	Check	Corrective Action
Defective Outlet Pressure Regulator	Verify that the Outlet Pressure Regulator can be adjusted	Replace Outlet Pressure Regulator if unable to adjust pressure (section 11.2)
Low Outlet Pressure Alarm set point lower than default setting	Verify Low Outlet Pressure Alarm set point	Adjust Outlet Pressure Regulator so that Outlet Pressure (OUTLET) reading drops below verified set point (section 9.15)
Defective Control Board	Verify that the Outlet Pressure (OUTLET) reading is lower than the Low Outlet Pressure Alarm set point (above)	Replace Control Board (section 11.2) if Outlet Pressure (OUTLET) reading is under verified Low Outlet Pressure Alarm set point for more than 1 minute and fails to create an alarm.

13.9 High Humidity



CAUTION!

Do not test the Humidity Sensor with an ohm meter or apply any DC voltage. This will render the Humidity Sensor defective.

Possible Cause	Check	Corrective Action
Low System Pressure	Verify System Pressure	Adjust System Pressure.
Low Flow Rate	Verify Flow Rate (FLOW) reading is low	Adjust the Bleed Orifice fitting to maintain a constant air flow. (section 6.5.19) Raise capacity control setting to 90 PSI (620.5 KPa). (section 6.5.13)
High Humidity Alarm set point too low	Verify High Humidity Alarm set point If Flow Rate is low, allowing a higher alarm set point (up to 10%) will allow dryer to run within acceptable levels.	Raise High Humidity Alarm set point Over 10% not recommended
Defective Humidity Sensor	Perform the Testing Humidity Alarm and System Shutdown test (section 9.13)	Troubleshoot <i>Can't Create a High Humidity Alarm / Shutdown</i> condition (section 13.10)
Heatless Dryer not cycling between towers	Verify consistent Heatless Dryer cycling (section 9.6)	Troubleshoot <i>Inconsistent Heatless Dryer Cycling</i> condition (section 13.13)
Defective Control Board	Unplug Humidity Sensor from Control Board (see section 11.1 for Board location) Humidity reading should drop to 0%	If Humidity did not drop to 0%, replace Control Board (section 11.2)

13.10 Can't Create a High Humidity Alarm / Shutdown

These troubleshooting steps assume that the Humidity Element is removed from the Humidity Block during the *Testing Humidity Alarm and System Shutdown* (section 9.13) procedures.

Possible Cause	Check	Corrective Action
Humidity Sensor Cable disconnected	Verify that Humidity Sensor cable is connected to the Control Board	Connect Humidity Sensor cable
Defective Humidity Sensor	Verify that Humidity reading fails to climb higher than 15% or creates sporadic readings	Replace Humidity Sensor (section 11.1)
Defective Control Board	Verify that Humidity reading is over 15% for more than 1 minute	Replace Control Board if no alarm is created and system does not shut down (section 11.2)

13.11 High Flow Rate Alarm

Possible Cause	Check	Corrective Action
Air leak in downstream cable outside of dryer	Verify Flow Rate (FLOW) reading is not higher than expected	Fix downstream problem
Air leak inside of dryer	Test fittings and hoses for leaks (section 9.16)	Reconnect or replace bad fitting / hose
High Flow Alarm set point too low	Verify High Flow Alarm set point	Raise High Flow Alarm set point

13.12 High Cabinet Temperature Alarm

Possible Cause	Check	Corrective Action
Fan Failure	Verify fan is running (section 9.9)	Check for loose fan wiring (section 14.1) Replace defective fan (section 11.1)
High Ambient Temperature	Verify temperature of dryer operating location. Recommended ambient temperature is 40°-85°F (4.4°-29.4°C)	Lower the ambient temperature of the dryer's operating location

13.13 Inconsistent Heatless Dryer Cycling

Possible Cause	Check	Corrective Action
Defective Solenoid Valve	Measure voltage going to the Heatless Dryer Solenoid Valves (section 9.8)	If voltage IS present, replace Solenoid Valves included in the 8,000 Hour Maintenance Kit (section 11.4)
Defective Cycle Timer	Measure voltage going to the Heatless Dryer Solenoid Valves (section 9.8)	If voltage IS NOT present, replace the Cycle Timer (section 11.3)

13.14 Compressor Doesn't Operate

Possible Cause	Check	Corrective Action
System is in Shutdown state	On the Display Panel, verify that the system is in SHUTDOWN state	Press the RESET Button
Defective Compressor	Measure Compressor voltage (section 9.3)	If voltage is good, replace Compressor (section 11.2) or send it in for repair (section 12.)
No power to Compressor	Measure Compressor voltage (section 9.3)	If voltage is not present or fluctuates, continue to next Possible Cause
Defective Solid-State Relay	Measure AC voltages at Solid State Relay (section 9.5)	If measurements are bad, replace Solid State Relay (section 11.1)
Defective Control Board	Measure DC voltages at Solid State Relay (section 9.5)	If measurements are incorrect, replace Control Board (section 11.2)

13.15 Compressor Won't Build Pressure

Possible Cause	Check	Corrective Action
Low System Pressure	Verify System Pressure	Adjust System Pressure.
Defective Unloader Valve	Test Unloader Valve operation (section 9.7) If this is continuously flowing high amounts	Replace Unloader Valve (section 11.2)

	of air, the Unloader Valve is defective.	
Leak in air system	Check all hoses and fittings between Compressor and Air Tank for air leaks (section 9.16)	Connect, tighten, or replace leaking component

13.16 Compressor Excessive AMP Draw

Possible Cause	Check	Corrective Action
Restriction in air line	Remove Discharge Hose from Compressor (hose to the heatless dryer) Re-measure Compressor AMP Draw (section 9.2)	If measurement is below the recommended amps, trace hoses from Compressor to Unloader Valve looking for restrictions or kinks
Compressor failing	Remove Discharge Hose from Compressor (hose to the heatless dryer) Re-measure Compressor AMP Draw (section 9.2)	If measurement is still above the recommended amps, replace the Compressor (section 11.2) or send it in for repair (section 12.)

13.17 High Compressor Last Run Time Alarm

Possible Cause	Check	Corrective Action
Low System Pressure	Verify System Pressure	Adjust System Pressure
High Flow condition	Verify Flow Rate (FLOW) reading is not higher than expected	Troubleshoot High Flow condition (section 13.11)
Defective Unloader Valve	Test Unloader Valve operation (section 9.7) If this is continuously flowing high amounts	Replace Unloader Valve (section 11.2)

	of air, the Unloader Valve is defective.	
Defective Heatless Dryer Solenoid Valve	Verify consistent Heatless Dryer cycling (section 9.6) If either side is continuously flowing high amounts of air, the Solenoid Valve is defective.	Replace Solenoid Valves included in the 8,000 Hour Maintenance Kit (section 11.4)
Defective Solid-State Relay	Measure AC voltages at Solid State Relay (section 9.5)	If measurements are bad, replace Solid State Relay (section 11.1)
Defective Control Board	Measure DC voltages at Solid State Relay (section 9.5)	If measurements are incorrect, replace Control Board (section 11.2)

13.18 Can't Create a High Compressor Last Run Time Alarm

Possible Cause	Check	Corrective Action
High Compressor Last Run Time Alarm Set Point higher than the default of 3:00 minutes	Verify High Compressor Last Run Time Alarm Set Point	Allow the Compressor to run longer than the verified set point (section 9.12)
Defective Control Board	Verify that the Compressor has run longer than the verified High Compressor Last Run Time Alarm Set Point (above)	Replace Control Board (section 11.2) if the Compressor runs longer than the verified High Compressor Last Run Time Alarm Set Point by 1 minute or more and fails to create an alarm.

13.19 Compressor Rapid ON/OFF Cycling

Possible Cause	Check	Corrective Action
Defective Solid-State Relay	Measure AC voltages at Solid State Relay (section 9.5)	If measurements are bad, replace Solid State Relay (section 11.1)
Defective Control Board	Measure DC voltages at Solid State Relay (section 9.5)	If measurements are incorrect, replace Control Board (section 11.2)

13.20 Contacting ALTEC AIR Technical Support

Please read the *Before You Call ALTEC AIR* section (13.1)

Once you have exhausted all of the potential problems and solutions covered in the *Troubleshooting Your Dryer* section, and you still require further assistance to correct a problem, contact ALTEC AIR Technical Support:

(800) 521-5351 (option 1)

Have the following information available:

Trouble Ticket # (if following-up on a previous call): _____
Technician Name: _____ **Phone #:** _____
Model #: _____ **Serial #:** _____
Company Name: _____ **Location Name:** _____
City: _____ **State:** _____

14. Appendix

14.1 Wiring Diagram

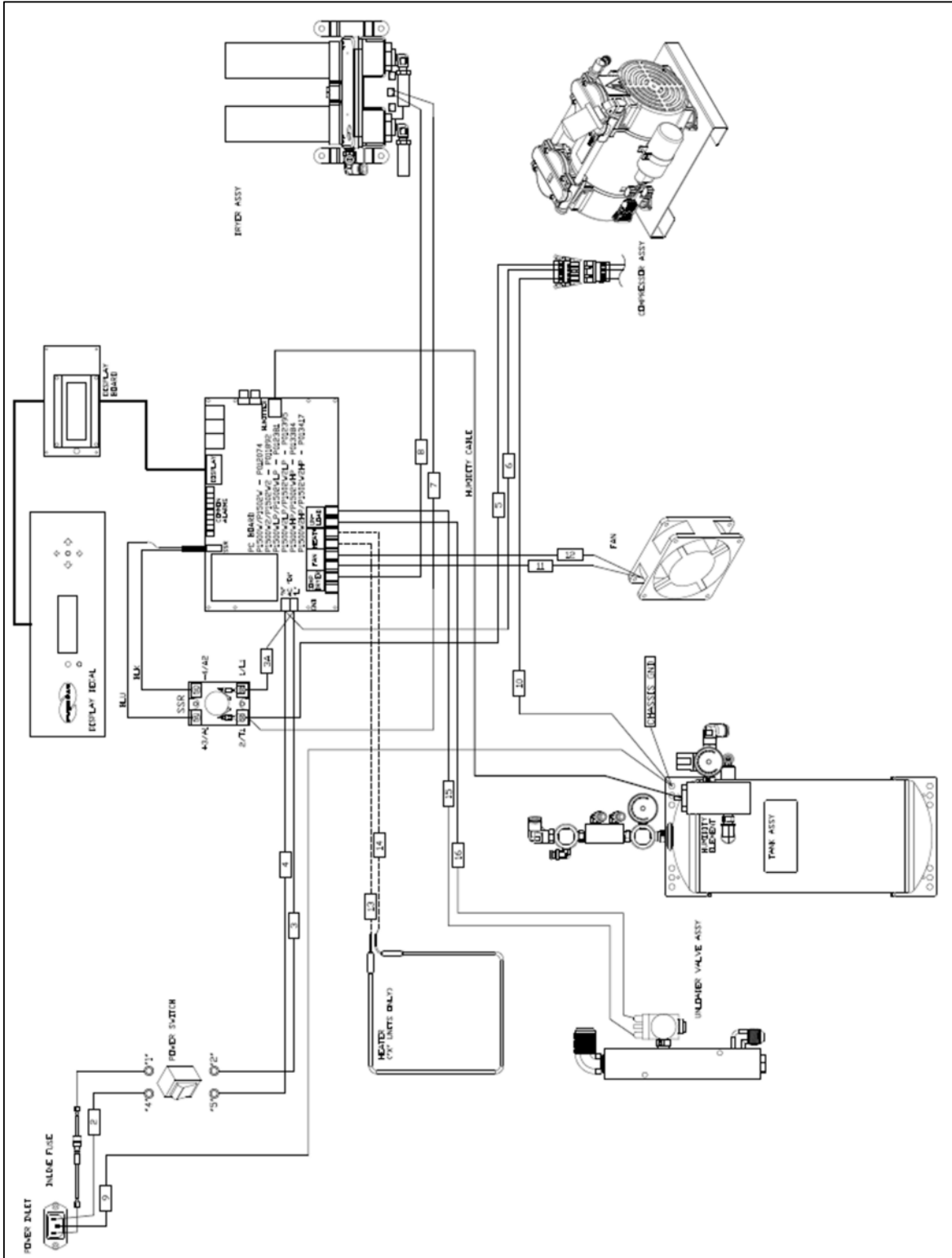

14.2 Set Point Limits and Defaults

14.2.1 System Adjustments

Description	Minimum Value	Maximum Value	Default Value	Unit of Measurement
System Pressure W & WLP WHP			80 (551.6) 90 (620.5)	PSI (KPa)
Static Pressure W & WLP WHP			17 (117.2) 60 (413.7)	PSI (KPa)
Outlet Pressure W WLP WHP	2.0 (13.8) 0.30 (2.1) 2.0 (13.8)	15.0 (103.4) 7.50 (51.7) 60.0 (413.7)		PSI (KPa)
Alarm Delay	OFF	ON	ON	
Startup Delay	0	10	0	Seconds

14.2.2 Alarm Set Points

Description	Minimum Value	Maximum Value	Default Value	Unit of Measurement	Shut down
High Flow Rate Alarm W & WLP WHP	0 0	2000 (56.6) 1000 (28.2)	1500 (42.5) 1000 (28.2)	SCFD (SCMD)	
High Outlet Pressure Alarm W WLP WHP	0.6 (4.1) 0.31 (2.1) 0.6 (4.1)	20.0 (137.9) 7.50 (51.7) 60.0 (413.7)	12.0 (82.7) 7.50 (51.7) 35.0 (241.3)	PSI (KPa)	
Low Outlet Pressure Alarm W WLP WHP	0.5 (3.4) 0.30 (2.1) 0.5 (3.4)	19.9 (137.2) 7.49 (51.6) 59.9 (412.9)	6.5 (44.8) 0.30 (2.1) 25.0 (172.4)	PSI (KPa)	
High Humidity Alarm	3	15	10	%	YES
High Compressor Last Run Time Alarm	2:00	5:00	3:00	Minutes	
High Cabinet Temperature Alarm			120 (48.9)	Deg F (Deg C)	YES
Compressor Total Run Time Alarm			8000	Hours	

14.2.3 System Operations

Description	ON Value	OFF Value	Default Value	Unit of Measurement
Compressor W & WLP WHP	25.0* (172.4)* 60.0 (413.7)	90.0 (620.5) 90.0 (620.5)		PSI (KPa)
Fan	90 (32.2)	80 (26.7)		Deg F (Deg C)

*(50 – 90 PSI (344.7 – 620.5 KPa) for Dryers using Firmware v2.84 and older)

14.3 SNMP Parameters

Device Configuration Information

Device ID	Alphanumeric (Defined by Customer)
Device Model	Alphanumeric (Factory Preset)
Device Firmware Version	Numeric (Factory Preset)
Current Date/Time	Numeric (mm/dd/yy hh:mm)
IP Address	Numeric (xxx.xxx.xxx.xxx)
Subnet Mask	Numeric (xxx.xxx.xxx.xxx)
Gateway Address	Numeric (xxx.xxx.xxx.xxx)
SNMP Trap Server Address	Numeric (xxx.xxx.xxx.xxx)
SNMP Read Community String (also sets SNMP Trap Community String)	Alphanumeric (6-14 digits, Default = "public")
SNMP Write Community	Alphanumeric (6-14 digits, Default = "123456")

Status Readings (Read-Only)

Outlet Pressure Reading	Numeric (PSI (KPa))
Tank Pressure Reading	Numeric (PSI (KPa))
Humidity Reading	Numeric (%)
Flow Reading	Numeric (SCFD (SCMD))
Cabinet Temperature Reading	Numeric (DEG F (DEG C))
Compressor Total Run Time Reading	Numeric (Hours)
Compressor Last Run Time Reading	Numeric (Seconds)
System Status	ON / SHUTDOWN
Compressor Status	ON / OFF
Fan Status	ON / OFF
Heater Status (Outdoor Unit Only)	ON / OFF

Alarm Readings (Read-Only)

High Flow Alarm	OK / Alarm
High Outlet Pressure Alarm	OK / Alarm
Low Outlet Pressure Alarm	OK / Alarm
High Humidity Alarm	OK / Alarm
High Cabinet Temperature Alarm	OK / Alarm
High Compressor Last Run Time Alarm	OK / Alarm
Maintenance Required Alarm	OK / Alarm
Total Alarm	OK / Alarm

Configuration Settings (Read-Write)

High Flow Alarm Threshold	Numeric (SCFD (SCMD))
High Outlet Pressure Alarm Threshold	Numeric (PSI (KPa))
Low Outlet Pressure Alarm Threshold	Numeric (PSI (KPa))
High Humidity Alarm Threshold	Numeric (%)
High Compressor Last Run Time Alarm Threshold	Numeric (Seconds)
Reset Compressor Total Run Time Reading	Numeric (Hours)
Start Up Delay	Numeric (Seconds)
Alarm Reset	RESET
Alarm Delay	ON / OFF

Alarm Traps Sent to SNMP Server

High Flow
High Outlet Pressure
Low Outlet Pressure
High Humidity
High Cabinet Temperature
High Compressor Last Run Time
Maintenance Required

15. Limited Warranty Agreement

ALTEC AIR products carry a one (1) year warranty against defective workmanship and material. This period starts at date of shipment. Not included are the components subject to normal replacement during a year's operating time.

No claims for labor in replacing defective parts or for consequential damages will be allowed. Replacement parts will be invoiced in the regular way, with invoices subject to adjustment after the parts claimed defective are examined at our factory. In addition, no material or parts will be accepted at our factory for in-warranty repairs or credit without previous authorization from ALTEC AIR.

Responsibility for damages incurred in transit will be borne by the user and the user in turn should file any damage claim against the carrier. All warranty items are F.O.B. Broomfield, Colorado. Freight charges are the responsibility of the user.

This warranty shall not apply to any ALTEC AIR product which shall have been repaired or altered in any way by anyone other than ALTEC AIR or authorized personnel so as to affect, in our judgment, its proper functioning or reliability, neither will it apply to any product which has been subject to misuse, negligence, or accident. The installation of unauthorized non ALTEC AIR parts will void the warranty on those ALTEC AIR products.

Registration Reminder

If you haven't already done so, please take a moment to register your ALTEC AIR P1500W Series Air Dryer. **Registering is necessary to activate this Limited Warranty on your product.** Once you register, you are eligible to receive free technical support, as well as updates concerning your ALTEC AIR products.

See Section 7. for details on Registering Your Dryer.

16. Contacting ALTEC AIR

16.1 General

ALTEC AIR, LLC
226A Commerce Street
Broomfield, Colorado 80020

(800) 521-5351

(303) 427-3700

Fax – (303) 657-2233

info@AltecAIR.com

www.AltecAIR.com

16.2 Sales

(800) 521-5351 (**option 2**)

Fax – (303) 657-2205

sales@AltecAIR.com

16.3 Service

(800) 521-5351 (**option 3**)

Fax – (303) 657-2205

16.4 Technical Support

(800) 521-5351 (**option 1**)

DON'T FORGET TO REGISTER YOUR DRYER!

See Section 7. for details on Registering Your Dryer.

